

safe · timeless · beautiful



markilux ES-X

Design and technology in perfect harmony



markilux ES-X

Design and technology in perfect harmony

- design features**
- Design and technology in perfect harmony
 - A designer awning made from brushed, marine grade stainless steel in a silky matt finish and other proven materials such as aluminium and galvanised steel.
 - Folding arms, torque bar and brackets have been powder coated in a self-cleaning finish, that provides a subtle contrast to the stainless steel.
 - End caps made of brass or copper increase the uniqueness of this awning.
 - when retracted the cover is protected from the weather by the cassette, which encloses it completely.

- technical highlights**
- Motor with integrated radio receiver and ergonomically crafted markilux hand held remote control as standard.
 - Unique arm technology with power transmission using a bionic tendon made of high-tech fibres with extremely high tensile strength.
 - The spring-tensioned modules - which have been matched to the awning extension - provide optimum cover tautness.
 - High lateral awning stability by virtue of the longer upper and shorter lower arm.
 - Folding arms with drop-forged aluminium moving components and Teflon-coated bronze bushes, which provide superior stability and longevity.

- optional accessories**
- An easily connected sun and wind sensor provides intelligent control and essential protection.
 - markilux infra-red heater in a compact aluminium housing. Caressing warmth without heating-up phase within an area of approx. 9-12 m²

- Attractively shaped brackets; Design down to the last detail
- A straight or wavy valance adds to the awning's appearance
- The panel joints of the awning cover are ultrasonically bonded to give an improved appearance without bothersome stitching
- Awning covers made of acrylic fabric or sunsilk snc with self-cleaning effect
- The 95 mm roller tube ensures the highest rigidity and the best possible cover winding characteristics even at the largest widths
- Sturdy, round steel torque bar, 50 mm Ø, to prevent twist and deflection
- Simple pitch adjustment without having to readjust the front profile.
- All screws and bolts are made of stainless steel

folding-arm cassette awning markilux ES-X



side view with awning closed, face fixture



side view with awning closed, top fixture



rolltex bearing



folding-arm with bionic tendon



Standard RAL colours:



standard:

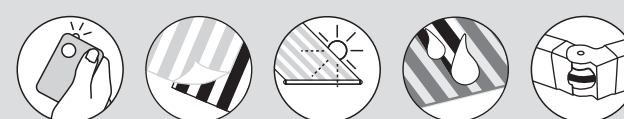

optional accessories:

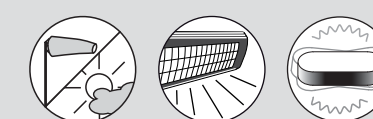

safe · timeless · beautiful



markilux *ES-X*

Design and technology in perfect harmony



dimensions and configuration options

extension	Overall blind width									minimum width motor ¹⁰⁾
	250 217-250	300 251-300	350 301-350	400 351-400	450 401-450	500 451-500	550 501-550	600 551-600	650 601-650	Standardarme
200	28)									230
250		28)								280
300			28)							330
350				28)						380

 = available, 2 folding arms

 = available, 2 folding arms, 1 Rolltex bearing

dimensions in cm

10) the dimensions are only valid for fixture without spreader plates (2 folding arms).

28) Please note the minimum widths!

operation type	
manual operation with st. steel winding handle	–
Servo-assisted operation	–
radio-controlled motor	●
motor	○
Shadeplus	
manual operation	–
radio-controlled motor	–
motor	–
Lighting	
Halogen Spotlights	–
Fluorescent lighting	–
covers	
acrylic 34 (fabric series 341xx-347xx)	●
sunsilk SNC (fabric series 324xx/329xx)	●
signature (fabric series 369xx)	●
transilk FR (fabric series 319xx)	–
transolair (fabric series 339xx)	–
widely woven acrylic (fabric series 349xx)	○ ¹
perla FR (fabric series 374xx/379xx)	○
Soltis 92	–
PVC fabric	○ ²
miscellaneous	
Coverboard	–
Sytem coverboard	–
wall sealing profile	–
Pitch adjustment gear	–
Insertable side blind	–
sun and wind sensor	○
Valance	● ¹
Infrared heater	○
Vibrabox / Sunis sun sensor	○
Coupled units (please refer to fixture)	
coupled unit 2 fields	–
coupled unit 3 fields	–
junction roller	–
one-piece cover (on request)	–

● = fitted as standard

○ = optional accessory

– = not available

○¹ = widely woven fabric up to a max. arm length of 300 cm; not possible in those dimensions that require a rolltex bearing

○² = PVC/Soltis 92 covers available up to a max. width of 600 cm and a max. arm length of 250 cm.



●¹ = valance shape 1 (please refer to the section "Fabric Collection")

Definition of extension: The extension is measured with the awning extended at a pitch of approx. 15° from the wall over the cover to the leading edge of the front profile. The extension tolerance is - 40mm / + 40mm

Extension when using a motor takes approximately 12 seconds per metre.

Coupled folding-arm awnings are not available.







frame colours

	marine grade brushed finish stainless steel	●
	5206 nano grey metallic	●
	non-standard RAL colour	–

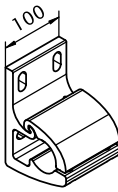
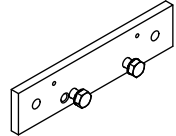
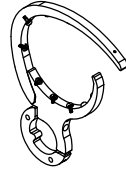
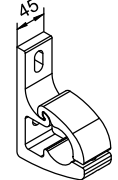
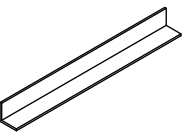
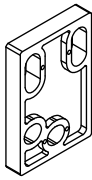
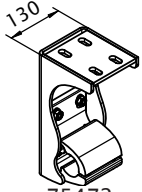
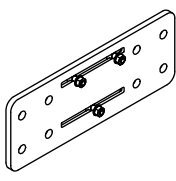
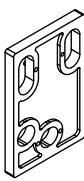
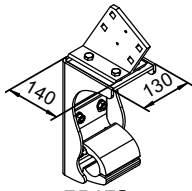
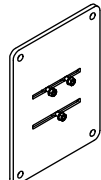
Folding arms, torque bar and fixture brackets are powder coated.

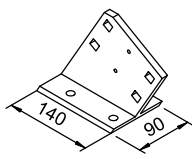
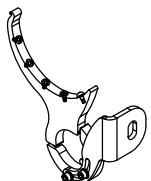

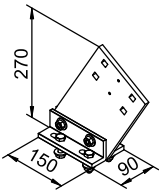
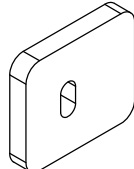
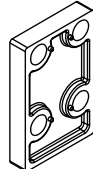
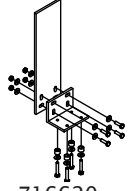
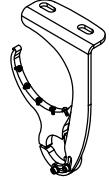
markilux ES-X

fixings and accessories

 <p>Face fixture bracket assembly 100 mm 70867.</p>	 <p>Additional eaves fixture plate 60x260x12 mm 75383.</p>	 <p>Storm safety clip assembly 724511</p>
 <p>Face fixture bracket assembly 45 mm 71813.</p>	 <p>Angled profile for eaves fixtures 100x100 mm available by the metre, undrilled 79380.</p>	 <p>Spacer plate for face fixture 100x150x20 mm N.B! stack to a max. of 200 mm 718231</p>
 <p>Top fixture bracket assembly 130 mm 75472.</p>	 <p>Component assembly spreader plate A 160x430x12 mm 75326.</p>	 <p>Spacer plate for face fixture 100x150x12 mm 718241</p>
 <p>eaves timber bracket assembly 140x130 mm 75473.</p>	 <p>Component assembly spreader plate B 300x400x12 mm 75325.</p>	 <p>Spacer plate for face fixture 45x150x20 mm N.B! stack to a max. of 200 mm 718251</p>
 <p>Eaves fixture bracket 140 mm 71612.</p>	 <p>Coverboard support assembly with wall bracket 754461</p>	 <p>Spacer plate for face fixture 45x150x12 mm 71826.</p>
 <p>Eaves fixture bracket assembly 270 mm 71659.</p>	 <p>Spacer for coverboard support 75447.</p>	 <p>Spacer plate for top fixture 90x140x20 mm N.B! stack to a max. of 200 mm 716311</p>
 <p>Angle and fixture plate for eaves fixture machine finish 716620</p>	 <p>Coverboard support assembly with top fixture bracket 754391</p>	 <p>Spacer plate for top fixture 90x140x12 mm 716411</p>

. = Please insert the RAL No. (please refer to the section on "Coatings")

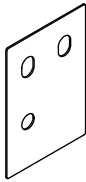
fixings and accessories

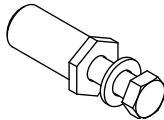
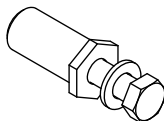
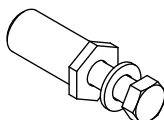
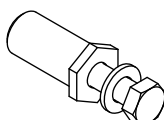
	Cover plate for external insulation
71833.	140x200x2mm
	Cover plate for external insulation
71834.	85x200x2mm
	reducing bolt assembly M 16 - M 12 / SW 27
753891	50mm length (please refer to "Technical Information")
	reducing bolt assembly M 10 - M 10 / SW 27
754901	50mm length (please refer to "Technical Information")
	reducing bolt assembly M 12 - M 10 / SW 27
754911	50mm length (please refer to "Technical Information")
	reducing bolt assembly M 16 - M 10 / SW 27
754921	50mm length (please refer to "Technical Information")

. = Please insert the RAL No. (please refer to the section on "Coatings")

Face fixture with spreader plate A

Pull-out force [N=Newton] per fixture point according to EN 13561, wind resistance class 2

		compression-proof substrate									non compression-proof substrate								
		M [cm]									M [cm]								
		250	300	350	400	450	500	550	600	650	250	300	350	400	450	500	550	600	650
H [cm]		FB [N]									FB [N]								
200		445	508	572	635	699	762	825	889	952	632	722	812	902	993	1083	1173	1263	1353
250		---	728	818	909	999	1090	1180	1271	1525	---	1034	1163	1292	1420	1549	1678	1806	2167
300		---	---	1089	1211	1333	1455	1775	1916	2056	---	---	1547	1721	1894	2068	2523	2722	2922
350		---	---	---	1616	1774	2177	2360	2543	---	---	---	---	2296	2521	3093	3353	3613	---
HT BHT		2 100 mm			2 100 mm			2 100 mm			2 100 mm			2 100 mm			2 100 mm		
		---			---			1 45 mm			---			---			1 45 mm		
BP		2			2			2			2			2			2		
DP		---			---			1			---			---			1		
DS		---			1			---			---			1			---		
BM		16			17			18			16			17			18		

The pull-out force refers to the vertical centre to centre measurement between the fixture points of 76 mm. In the case of spreader plates a washer conforming to DIN 9021 must be used.

M = overall awning width
H = extension
FB = pull-out force per fixing point
HT | BHT = bracket quantity | width
BP = no. of spreader plates
DP = no. of spacer plates
DS = Coverboard support with bracket
BM = no. of fixing points

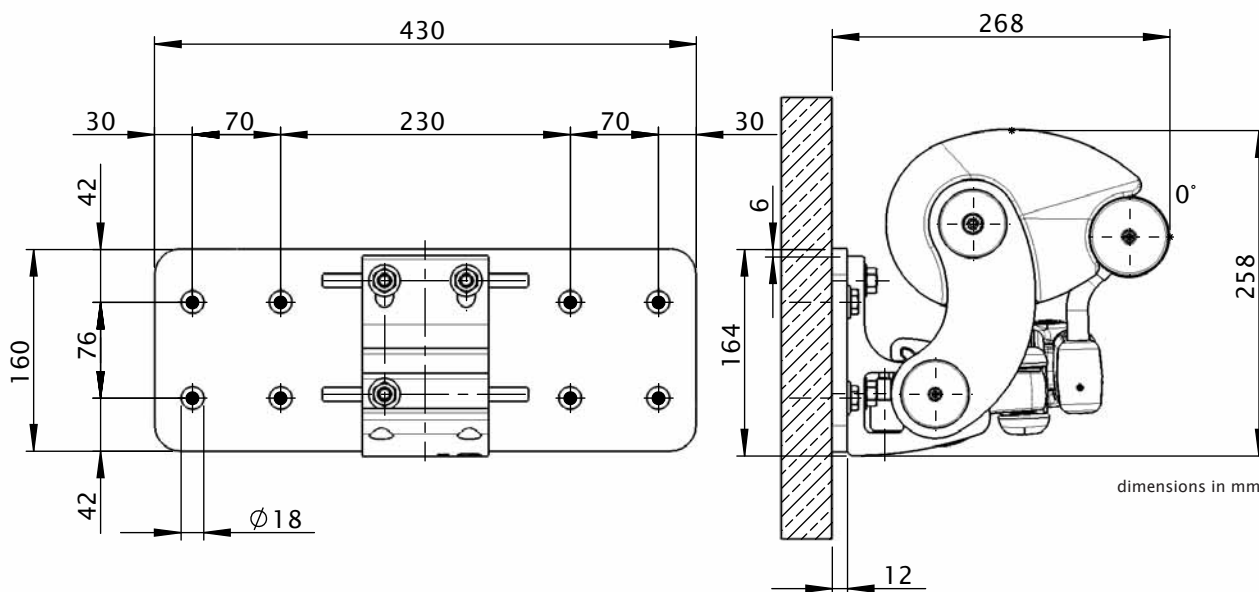

dimensions in mm

markilux ES-X

Face fixture with spreader plate B

Pull-out force [N=Newton] per fixture point according to EN 13561, wind resistance class 2

compression-proof substrate										non compression-proof substrate									
H [cm]	M [cm]									M [cm]									
	250	300	350	400	450	500	550	600	650	250	300	350	400	450	500	550	600	650	
FB [N]										FB [N]									
200	263	301	338	376	413	451	489	526	564	274	314	353	392	431	470	509	549	588	
250	---	431	484	538	591	645	699	752	902	---	449	505	561	617	673	729	784	941	
300	---	---	644	717	789	861	1051	1134	1217	---	---	672	747	823	898	1096	1182	1269	
350	---	---	---	956	1050	1288	1396	1505	---	---	---	---	997	1095	1343	1456	1569	---	
HT BHT	2 100 mm			2 100 mm			2 100 mm			2 100 mm			2 100 mm			2 100 mm			
	---			---			1 45 mm			---			---			1 45 mm			
BP	2			2			2			2			2			2			
DP	---			---			1			---			---			1			
DS	---			1			---			---			1			---			
BM	8			9			10			8			9			10			

The pull-out force refers to the vertical centre to centre measurement between the fixture points of 350 mm. In the case of spreader plates a washer conforming to DIN 9021 must be used.

M = overall awning width
H = extension
FB = pull-out force per fixing point
HT | BHT = bracket quantity | width
BP = no. of spreader plates
DP = no. of spacer plates
DS = Coverboard support with bracket
BM = no. of fixing points

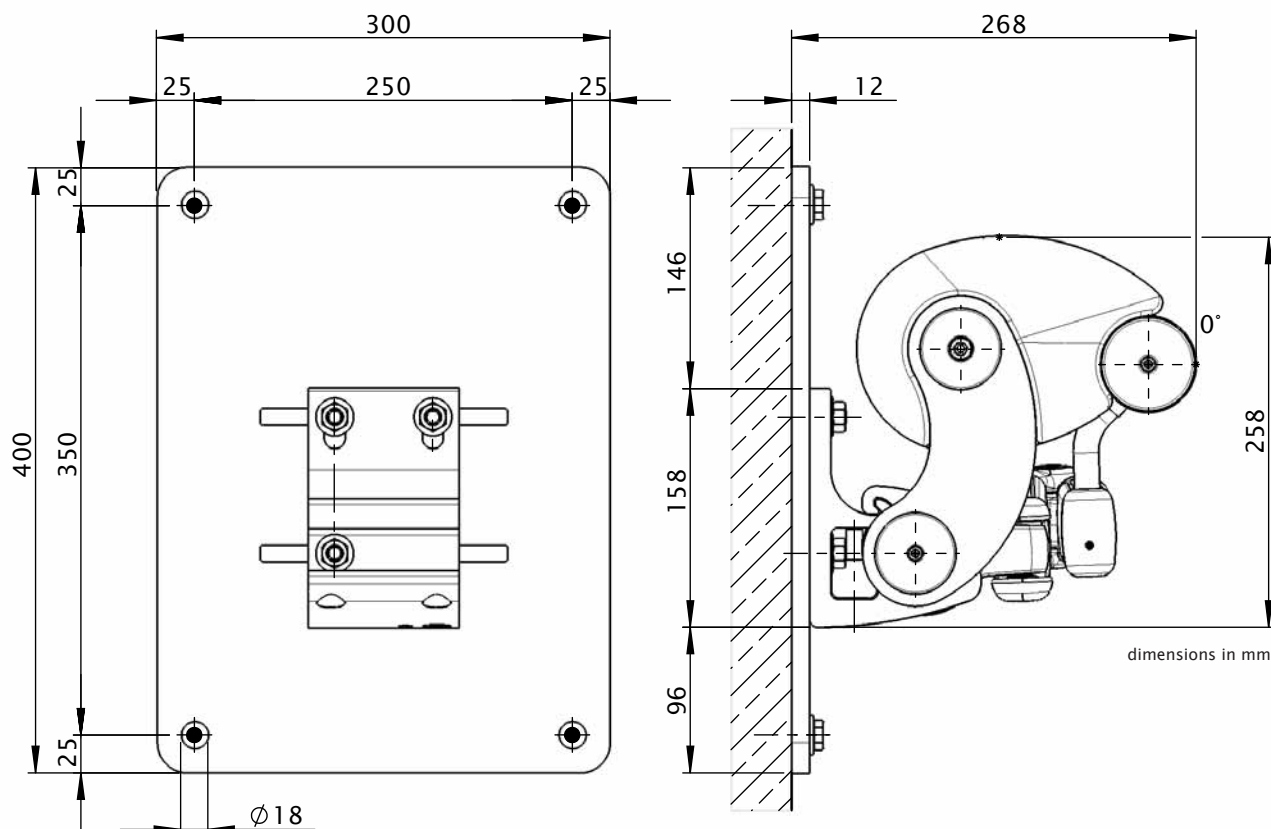

Top fixture

Pull-out force [N=Newton] per fixture point according to EN 13561, wind resistance class 2

H [cm]	compression-proof substrate									non compression-proof substrate								
	M [cm]									M [cm]								
	250	300	350	400	450	500	550	600	650	250	300	350	400	450	500	550	600	650
FB [N]	836	959	1082	1205	1328	1451	1574	1697	1820	1004	1151	1298	1445	1592	1739	1887	2034	2181
200	---	1343	1513	1684	1854	2024	2195	2365	2819	---	1619	1824	2029	2233	2438	2643	2847	3398
250	---	---	1987	2213	2438	2664	3234	3492	3749	---	---	2401	2673	2945	3217	3909	4220	4531
300	---	---	---	2921	3210	3925	4257	4589	---	---	---	---	3536	3885	4753	5154	5556	---
350	2 130 mm			2 130 mm			3 130 mm			2 130 mm			2 130 mm			3 130 mm		
HT BHT	---			1			---			---			1			---		
DS	8			10			12			8			10			12		
BM	---			---			---			---			---			---		

The pull-out force is calculated with reference to the horizontal centre to centre separation of the fixture points of 101 mm. If the awning is fitted with two brackets per folding arm the pull-out force may be halved. Position the brackets to the left and right of the arm bearer.

M = overall awning width
H = extension
FB = pull-out force per fixing point
HT | BHT = bracket quantity | width
DS = Coverboard support with bracket
BM = no. of fixing points

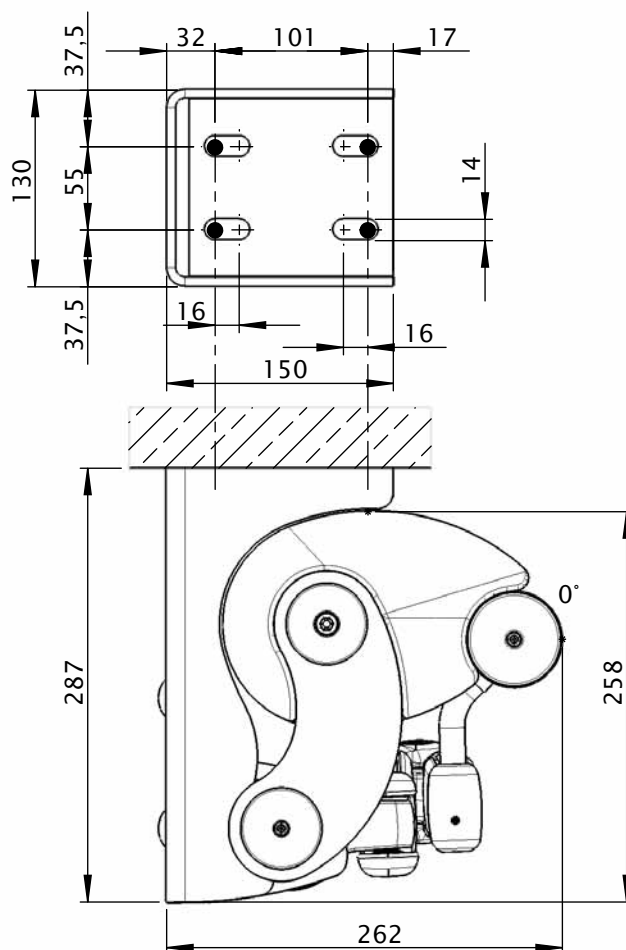

dimensions in mm

markilux ES-X

Eaves/Roof timber fixture

Torque [Nm = Newton metres] for the fixture bracket next to the arm, shear force [N = Newton] per fixture point in accordance with EN 13561, wind resistance class 2

H [cm]	Torque									shear force								
	M [cm]									M [cm]								
	250	300	350	400	450	500	550	600	650	250	300	350	400	450	500	550	600	650
	Md [Nm]									FS [N]								
200	86	103	121	138	155	173	190	208	225	2239	2566	2893	3220	3547	3874	4201	4528	4855
250	---	217	245	272	299	326	353	380	408	---	3616	4072	4529	4985	5441	5898	6354	7586
300	---	---	351	390	428	467	506	545	654	---	---	5367	5974	6582	7189	8740	9434	10129
350	---	---	---	520	572	625	762	822	---	---	---	---	7912	8691	10637	11535	12434	---
HT	2				3					2				3				
BM	8				12					8				12				

The shear force is calculated from 2 fixture points per bracket, because - depending on the roof pitch - it cannot be guaranteed that 4 fixture points per bracket can be used.

M = overall awning width
 H = extension
 Md = torque value for the bracket next to the arm
 FS = shear force
 HT = bracket
 BM = no. of fixing points

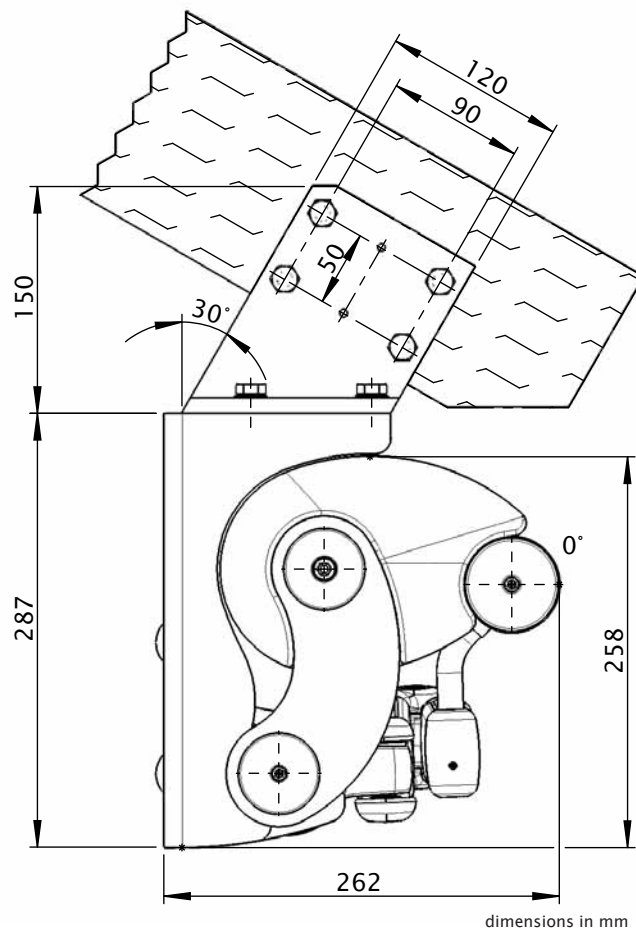

dimensions in mm

Eaves fixture with additional plate

Torque [Nm = Newton metres] for the fixture bracket next to the arm, shear force [N = Newton] per fixture point in accordance with EN 13561, wind resistance class 2

H [cm]	Torque										shear force									
	M [cm]										M [cm]									
	250	300	350	400	450	500	550	600	650	250	300	350	400	450	500	550	600	650		
	Md [Nm]										FS [N]									
200	86	103	121	138	155	173	190	208	225	1076	1237	1398	1559	1720	1881	2042	2202	2363		
250	---	217	245	272	299	326	353	380	408	---	1710	1929	2148	2367	2586	2805	3024	3593		
300	---	---	351	390	428	467	506	545	654	---	---	2511	2798	3085	3373	4084	4410	4737		
350	---	---	---	520	572	625	762	822	---	---	---	---	3670	4035	4924	5342	5760	---		
HT	2					3					2					3				
BM	4					6					4					6				

By using the additional flat plate, the shear force is reduced in comparison with conventional eaves fixture.

M = overall awning width
H = extension
Md = torque value for the bracket next to the arm
FS = shear force
HT = bracket
BM = no. of fixing points

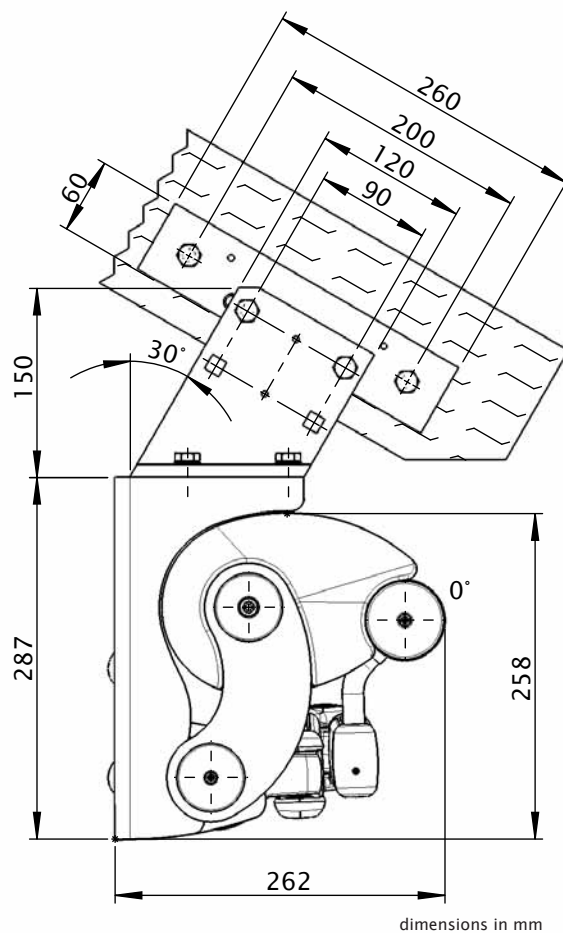

dimensions in mm

Bracket range for awnings with 2 folding arms

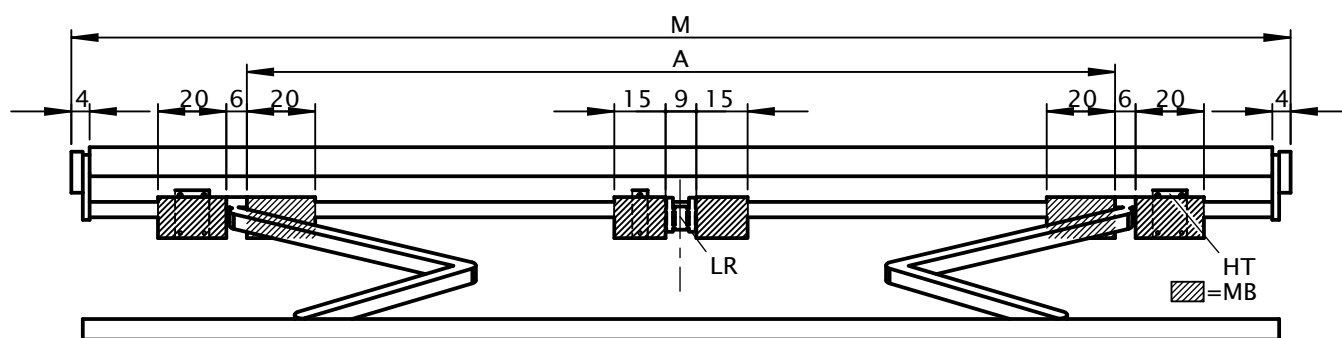

dimensions in cm

M [cm]	SB ZB	250 217-250	300 251-300	350 301-350	400 351-400	450 401-450	500 451-500	550 501-550	600 551-600	650 601-650
		A [cm]								
H [cm]	200	204 ▲	225	262	292	332	372	407	442	472
	250	---	254 ▲	275	292	332	372	407	442	472
	300	---	---	304 ▲	325	332	372	407	442	472
	350	---	---	---	354 ▲	375	387	407	442	---
W	HT BHT	45 mm	---				---	1		
		100 mm	2				2	2		
		+ DS	---				1	---		
DE	HT	130 mm	2				2	3		
		+ DS	---				1	---		
DA	HT	2				3	3			

dimensions in cm

▲ = Please note the minimum widths!

M = overall awning width
 A = arm position
 HT = bracket
 LR = Rolltex bearing with bracket is always situated under the central seam (depends on the width)
 MB = range for bracket fixture
 SB = standard width
 ZB = intermediate width
 H = extension
 W = face fixture
 HT | BHT = bracket quantity | width
 DE = top fixture
 DA = Eaves/roof timber fixture
 DS = Coverboard support with bracket

If the brackets cannot be positioned in accordance with this table, make sure the actual measurements are noted on the order form!