

safe · timeless · beautiful



markilux 5010

The cassette awning - slim, strong and simply stylish



markilux 5010

The cassette awning - slim, strong and simply stylish

- design features**
- The slim cassette awning with the elegant lines - from the design studio.
 - The cover profile is in the same colour as the cassette; This provides for an homogeneous appearance even when the awning is extended.
 - Attractive, rounded end caps complete the overall appearance of this slim cassette awning.
 - for long-lasting attractiveness the awning has been powder coated.
 - Attractive brackets; Design down to the last detail.

- technical highlights**
- Because of its superior design the markilux 5010 belongs to the sturdiest and most stable of awnings on the market in spite of its slender shape.
 - Front profile with integrated gutter and hidden water drainage spouts.
 - When closed the folding arms are protected from the weather by the cassette.
 - The extremely sturdy awning construction makes it possible to shade even very large areas safely.
 - The 85 mm roller tube ensures the highest rigidity and the best possible cover winding characteristics even at the largest widths.

- optional accessories**
- In the case of manual operation ease of use is ensured with the spring-assisted gearbox.
 - Hard-wired motor drive (optionally with automatic controls) for simple, relaxed operation.
 - Radio-controlled motor with handheld transmitter for ease of operation - and ergonomically crafted for ease of use.
 - The shadeplus creates an additional room on the patio. Protection from sun, wind and inquisitive glances in one.
 - Awning available in non-standard RAL colours

· Awning covers made from acrylic fabric or sunsilk snc with self-cleaning effect · The panel joints of the awning cover are ultrasonically bonded to give a better appearance without bothersome stitching · Manual operation includes a markilux stainless steel winding handle - quality to get to grips with · Folding arms with perfected power transference by means of double, rounded steel-link chains and direct coupling of the springs. The highest safety standards even at large extensions · Folding arms with drop-forged joint components made of aluminium. The pivot bolts sit in Teflon-coated bronze bushes for high stability and longevity · The greater upper to lower arm length ratio ensures high lateral stability in the awning · The use of cam bolts makes fine-tuning of the folding arms a simple procedure · Simply pitch adjustment via the bracket without necessitating readjustment of the front profile · Awnings more than 700 cm wide can be supplied as coupled units. · An easily installed sun and wind sensor provides intelligent control and essential protection · An optional wall sealing profile covers the gap between wall and awning · Available with a valance

folding-arm cassette awning markilux 5010



Neigungseinstellung über die Befestigungshalter



markilux 5010 with wall sealing profile (optional)



Face fixture bracket



side view showing gearbox eye for manual operation (standard)



during extension



corrosion-resistant and technically proven; twin steel-link chains at the elbow joints



Shadeplus (optional) retracted

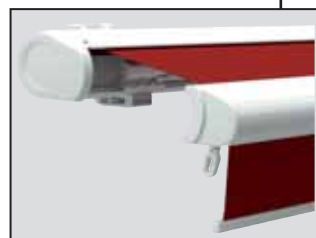

shadeplus (optional) during extension

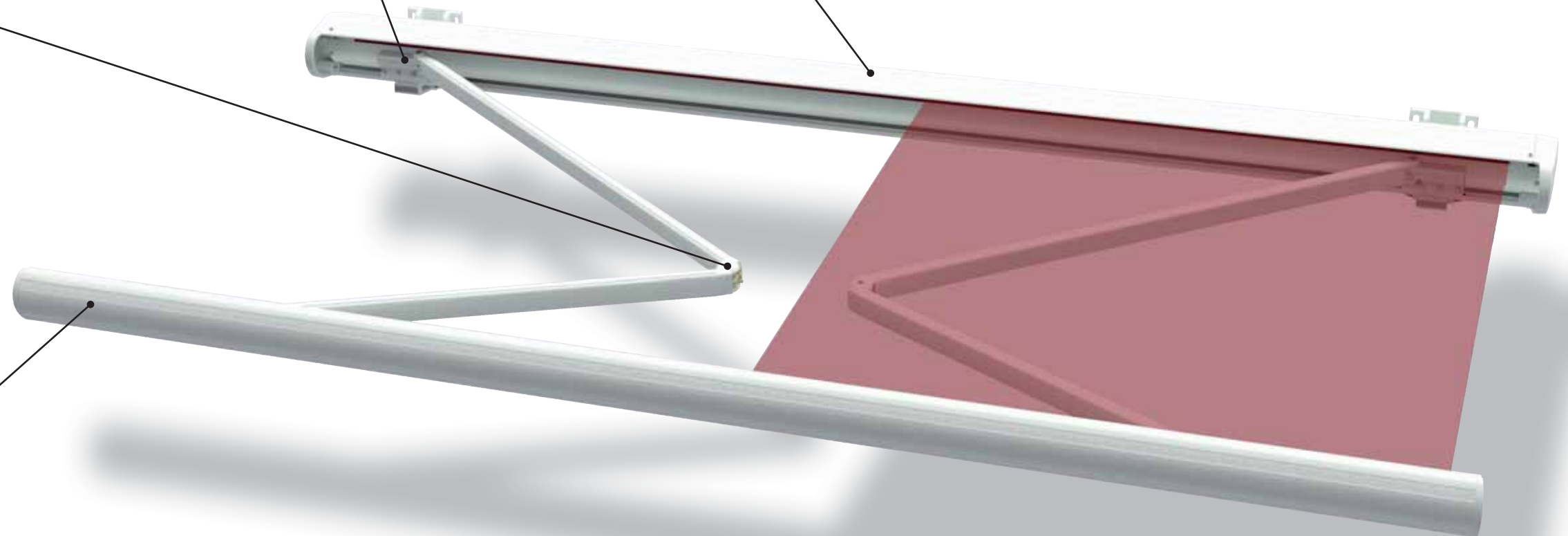

Standard RAL colours:



standard:

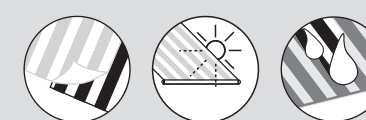

optional accessories:



safe · timeless · beautiful

markilux 5010



markilux 5010 Lounge

frame colours	End cap trim colours
Nano off-white textured finish 5233	Nano off-white textured finish 5233
Nano stone grey metallic 5215	Nano stone grey metallic 5215
Nano anthracite metallic 5204	Nano anthracite metallic 5204
	Polished chrome



markilux 5010

The cassette awning - slim, strong and simply stylish



dimensions and configuration options

extension	Overall blind width										minimum width motor ¹⁹⁾		minimum width manual operation ²⁰⁾	
	250 187-250	300 251-300	350 301-350	400 351-400	450 401-450	500 451-500	550 501-550	600 551-600	650 601-650	700 ²⁰⁾ 651-700	Standard	Bespoke arms	Standard	Bespoke arms
150	28)										200	187	200	187
200	28)										250	237	250	237
250		28)									300	287	300	287
300			28)				17)	27) 17)			350	337	350	337
350 ¹⁷⁾				28)				20) 21) 55)			400	387	400	387
400 ^{17) 19) 25)}					28)	24)	1)			1) 23) 54)	450	437	450	437

dimensions in cm

1) with one Rolltex bearing.

17) a shadeplus is not available

19) awnings with 4 m extension are only available with motor (surcharge).

20) no intermediate sizes possible below the standard width of 650 cm.

21) awnings with 3 arms are only available with motor (surcharge).

23) no intermediate sizes possible below the standard width of 700 cm.

24) rolltex bearing only from a width of 465 cm.

25) an extension of 400 cm is supplied without interior cover profile.

27) with shadeplus, 3 folding arms.

28) Please note the minimum widths!

54) smallest awning width with 3 arms 700 cm.

55) smallest awning width with 3 arms 641 cm.

 = available, 2 folding arms

 = available, 3 folding arms

Due to the compact awning construction and depending on the width and the arm length, contact between cover and folding arms may occur during extension and retraction. This does not affect the functionality or longevity of the awning.

operation type	
manual operation with st. steel winding handle	●
Servo-assisted operation	○
radio-controlled motor	○
motor	○
Shadeplus	
manual operation	○
radio-controlled motor	–
motor	–
Lighting	
Halogen Spotlights	–
Fluorescent lighting	–
covers	
acrylic 34 (fabric series 341xx-347xx)	●
sunsilk SNC (fabric series 324xx/329xx)	●
signature (fabric series 369xx)	●
transilk FR (fabric series 319xx)	–
transolair (fabric series 339xx)	–
widely woven acrylic (fabric series 349xx)	–
perla FR (fabric series 374xx/379xx)	○
Soltis 92	○ ²
PVC fabric	○ ²
miscellaneous	
Coverboard	–
Sytem coverboard	–
wall sealing profile	○ ³
Pitch adjustment gear	–
Insertable side blind	○
sun and wind sensor	○
Valance	○
Infrared heater	○
Vibrabox / Sunis sun sensor	○
Coupled units (please refer to fixture)	
coupled unit 2 fields	○
coupled unit 3 fields	○
junction roller	○
one-piece cover (on request)	○

● = fitted as standard

○ = optional accessory

– = not available

○² = PVC/Soltis 92 covers available up to a max. width of 600 cm and a max. arm length of 250 cm.○³ = wall sealing profile effective up to an awning pitch of 35°

Definition of extension: The extension is measured with the awning extended at a pitch of approx. 15° from the wall over the cover to the leading edge of the front profile. The extension tolerance is - 40mm / + 40mm

In the case of manual operation, assume approx. 16 winding handle revolutions per metre of awning extension.

Extension when using a motor takes approximately 12 seconds per metre.

Definition of shadeplus drop: The shadeplus drop is measured from the bottom edge of the shadeplus profile to the bottom edge of the valance profile. Because of tolerances in fabric thicknesses the drop may be shorter by up to 5 cm.

A shadeplus with gear is available in drops of 150 cm and 190 cm.

A shadeplus is not possible with PVC covers.

A shadeplus with motor is not possible.









coupled folding-arm awnings are available up to a max. of 3 single units side by side, however only with 6 folding-arms at most and only motorised.

Optionally available with **junction roller**. Pattern repeat mismatches are possible in the case of junction roller covers.

except when the extension is the maximum for the width of each awning. (see also arm separation table)

one-piece awning covers only on request.

If coupled awnings are to be fitted into a **recess** or **reveal** the overall width of the coupled blind or awning must be at least 6 cm less than the width of the opening to allow the blind/awning to be coupled. Make a special note if the awning is to be fitted into a recess/reveal and note the reveal width separately.

frame colours		
	RAL 9016 traffic white	●
	RAL 8019 grey brown	●
	RAL 9006 metallic aluminium	●
	RAL 1015 light ivory	●
	5204 Nano anthracite metallic 5204 (Lounge)	○
	5215 Nano stone grey metallic 5215 (Lounge)	○
	5233 Nano off-white textured finish (Lounge)	○
	non-standard RAL colour	○

markilux 5010

fixings and accessories

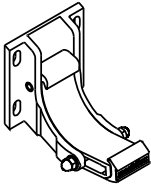
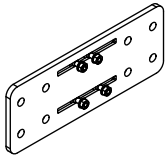
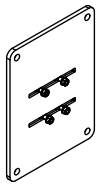
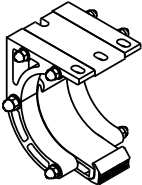
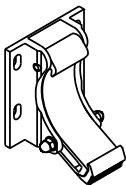
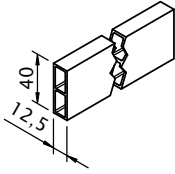
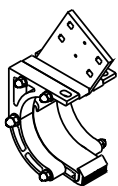
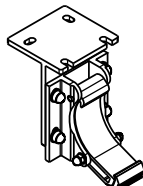
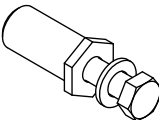
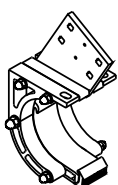
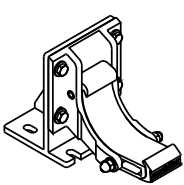
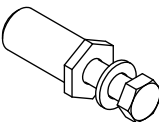
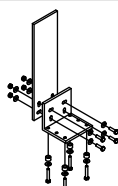
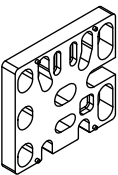
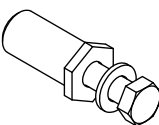
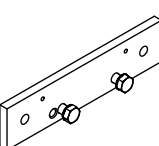
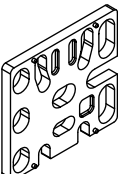
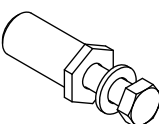
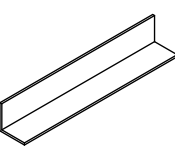
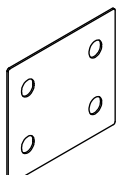
 77921.	Face fixture bracket assembly 150mm 5 - 35°	 75328.	Component assembly spreader plate A 160x430x12mm	 75327.	Component assembly spreader plate B 300x400x12mm
 77937.	Top fixture bracket assembly 135mm 5 - 35°	 77936.	Face fixture bracket assembly 150mm 38 - 65°	 751971	stand-off strip for wall sealing profile available by the metre Fixture example, see face fixture with wall sealing profile
 77939.	Eaves fixture bracket assembly 5 - 35°	 77938.	Top fixture bracket assembly 150mm 38 - 65°	 753891	reducing bolt assembly M 16 - M 12 / SW 27 50mm length (please refer to "Technical Information")
 77940.	Eaves fixture bracket assembly 270mm	 77941.	Bottom fixture bracket assembly 5 - 35°	 754901	reducing bolt assembly M 10 - M 10 / SW 27 50mm length (please refer to "Technical Information")
 741290	Angle and fixture plate for eaves fixture machine finish	 716331	Spacer plate face/ top fixture 136x150x20mm N.B! stack to a max. of 200 mm	 754911	Reduction assembly M 12 - M 10 / SW 27 50mm length (please refer to "Technical Information")
 75383.	Additional eaves fixture plate 60x260x12mm	 71644.	Spacer plate face/ top fixture 136x150x12mm	 754921	reducing bolt assembly M 16 - M 10 / SW 27 50mm length (please refer to "Technical Information")
 701809	angled profile 160x160x12mm available by the metre, undrilled	 71837.	Cover plate for external insulation 178x190x2mm		

. = Please insert the RAL No. (please refer to the section on "Coatings")

Face fixture

Pull-out force [N=Newton] per fixture point according to EN 13561, wind resistance class 2

H [cm]	compression-proof substrate										non compression-proof substrate									
	M [cm]										M [cm]									
	250	300	350	400	450	500	550	600	650	700	250	300	350	400	450	500	550	600	650	700
	FB [N]										FB [N]									
150	505	583	661	739	816	894	972	1050	1127	935	578	667	756	845	934	1023	1112	1201	1290	1070
200	834	957	1079	1202	1324	1447	1569	1692	1815	1603	955	1095	1235	1376	1516	1656	1796	1936	2077	1834
250	---	1364	1541	1717	1894	2071	2247	2424	2937	2622	---	1561	1763	1965	2167	2370	2572	2774	3361	3001
300	---	---	2079	2319	2559	2799	3447	3726	4004	3597	---	---	2379	2654	2929	3204	3945	4264	4582	4117
350	---	---	---	3101	3415	4231	4596	4961	4653	4929	---	---	---	3549	3908	4842	5260	5678	5326	5642
400	---	---	---	---	4874	5337	5801	---	---	6233	---	---	---	---	5578	6108	6638	---	---	7133
HT BHT	2 150 mm				3 150mm				4 150 mm		2 150 mm				3 150mm				4 150 mm	
BM	8				12				16		8				12				16	

The pull-out force refers to the vertical centre to centre measurement between the fixture points of 90 mm. If this measurement is reduced, the pull-out force increases by 2% in the case of **compression-proof** substrates and by 19% in the case of **non-compression-proof** substrates.

M = overall awning width
H = extension
FB = pull-out force per fixing point
HT | BHT = bracket quantity | width
BM = no. of fixing points
WA = wall sealing profile

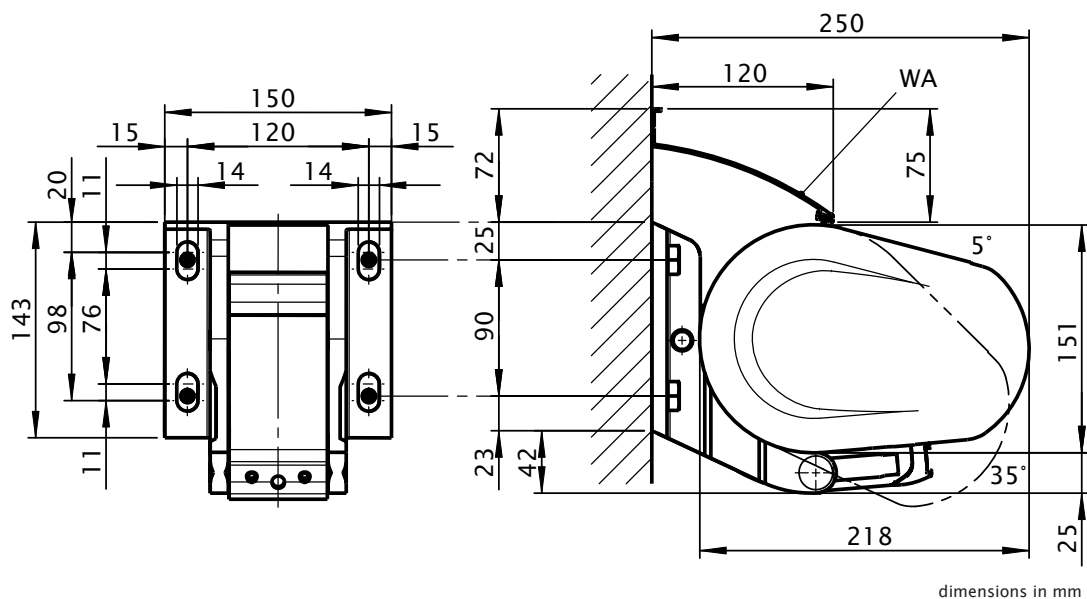

markilux 5010

Face fixture with spreader plate A

Pull-out force [N=Newton] per fixture point according to EN 13561, wind resistance class 2

compression-proof substrate												non compression-proof substrate											
H [cm]	M [cm]											M [cm]											
	250	300	350	400	450	500	550	600	650	700	250	300	350	400	450	500	550	600	650	700			
FB [N]												FB [N]											
150	244	282	319	357	394	432	469	507	544	428	347	400	453	507	560	613	667	720	773	608			
200	402	461	520	579	638	697	756	815	874	725	571	655	739	822	906	990	1074	1158	1241	1031			
250	---	656	741	825	910	995	1080	1165	1412	1195	---	932	1052	1173	1294	1414	1535	1655	2006	1699			
300	---	---	998	1113	1229	1344	1655	1789	1922	1641	---	---	1418	1582	1746	1910	2352	2542	2732	2332			
350	---	---	---	1488	1638	2030	2205	2380	2100	2233	---	---	---	2114	2328	2884	3133	3382	2985	3174			
400	---	---	---	---	2337	2559	2781	---	---	2827	---	---	---	---	3320	3636	3952	---	---	4017			
HT BHT	2 150 mm			3 150 mm			4 150 mm			2 150 mm			3 150 mm			4 150 mm							
BP	2			2			3			2			2			3							
DP	---			1			1			---			1			1							
BM	16			20			28			16			20			28							

The pull-out force refers to the vertical centre to centre measurement between the fixture points of 76 mm. In the case of spreader plates a washer conforming to DIN 9021 must be used.

- M = overall awning width
- H = extension
- FB = pull-out force per fixing point
- HT | BHT = bracket quantity | width
- BP = no. of spreader plates
- DP = no. of spacer plates
- BM = no. of fixing points
- WA = wall sealing profile
- 75197.: stand-off strip for wall sealing profile

markilux 5010

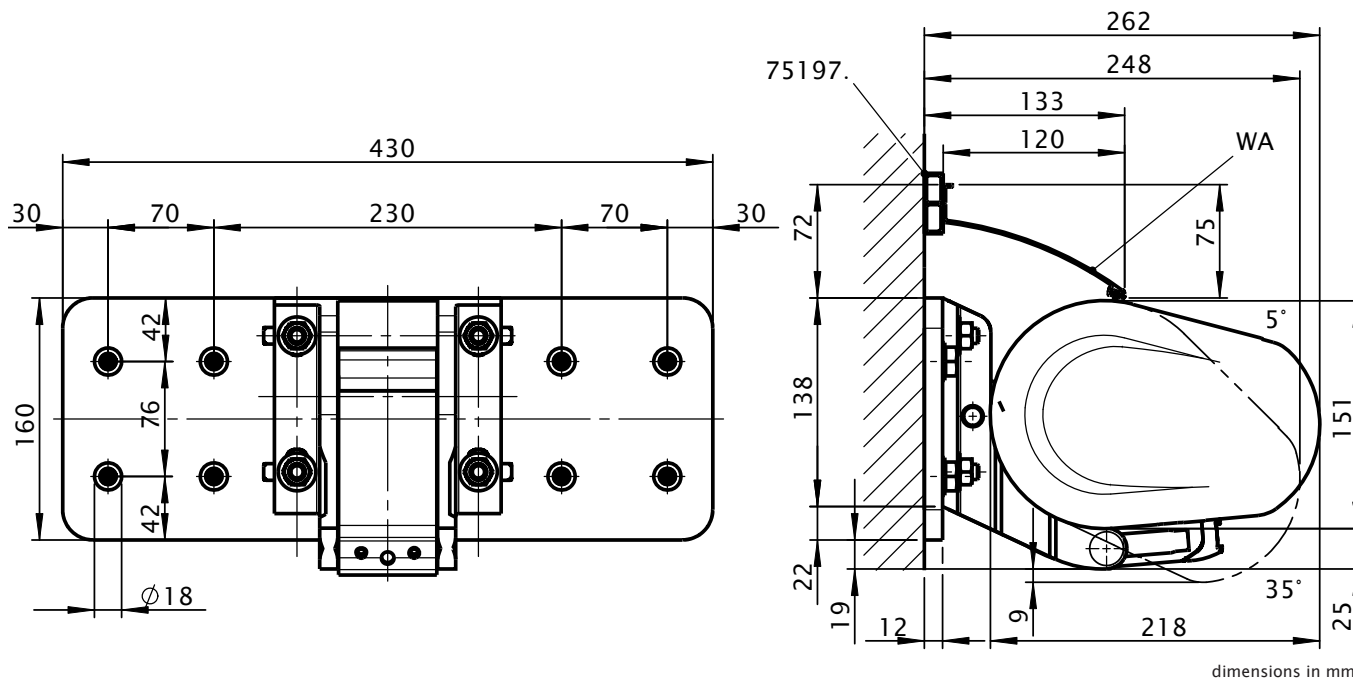

Face fixture with spreader plate B

Pull-out force [N=Newton] per fixture point according to EN 13561, wind resistance class 2

H [cm]	compression-proof substrate										non compression-proof substrate									
	M [cm]										M [cm]									
	250	300	350	400	450	500	550	600	650	700	250	300	350	400	450	500	550	600	650	700
	FB [N]										FB [N]									
150	144	167	189	211	233	255	278	300	322	253	151	174	197	220	243	266	289	313	336	264
200	238	273	308	342	377	412	447	482	517	429	248	284	321	357	394	430	466	503	539	448
250	---	388	438	488	539	589	639	689	835	707	---	405	457	509	562	614	667	719	871	738
300	---	---	591	659	727	795	979	1059	1138	971	---	---	616	687	758	829	1021	1104	1186	1013
350	---	---	---	880	969	1201	1305	1408	1243	1322	---	---	---	918	1011	1253	1361	1469	1296	1378
400	---	---	---	---	1383	1514	1646	---	---	1673	---	---	---	---	1442	1579	1716	---	---	1744
HT BHT	2 150 mm				3 150 mm				4 150 mm		2 150 mm				3 150 mm				4 150 mm	
BP	2				2				3		2				2				3	
DP	---				1				1		---				1				1	
BM	8				12				16		8				12				16	

The pull-out force refers to the vertical centre to centre measurement between the fixture points of 350 mm. In the case of spreader plates a washer conforming to DIN 9021 must be used.

- M = overall awning width
- H = extension
- FB = pull-out force per fixing point
- HT | BHT = bracket quantity | width
- BP = no. of spreader plates
- DP = no. of spacer plates
- BM = no. of fixing points
- 75197.: stand-off strip for wall sealing profile

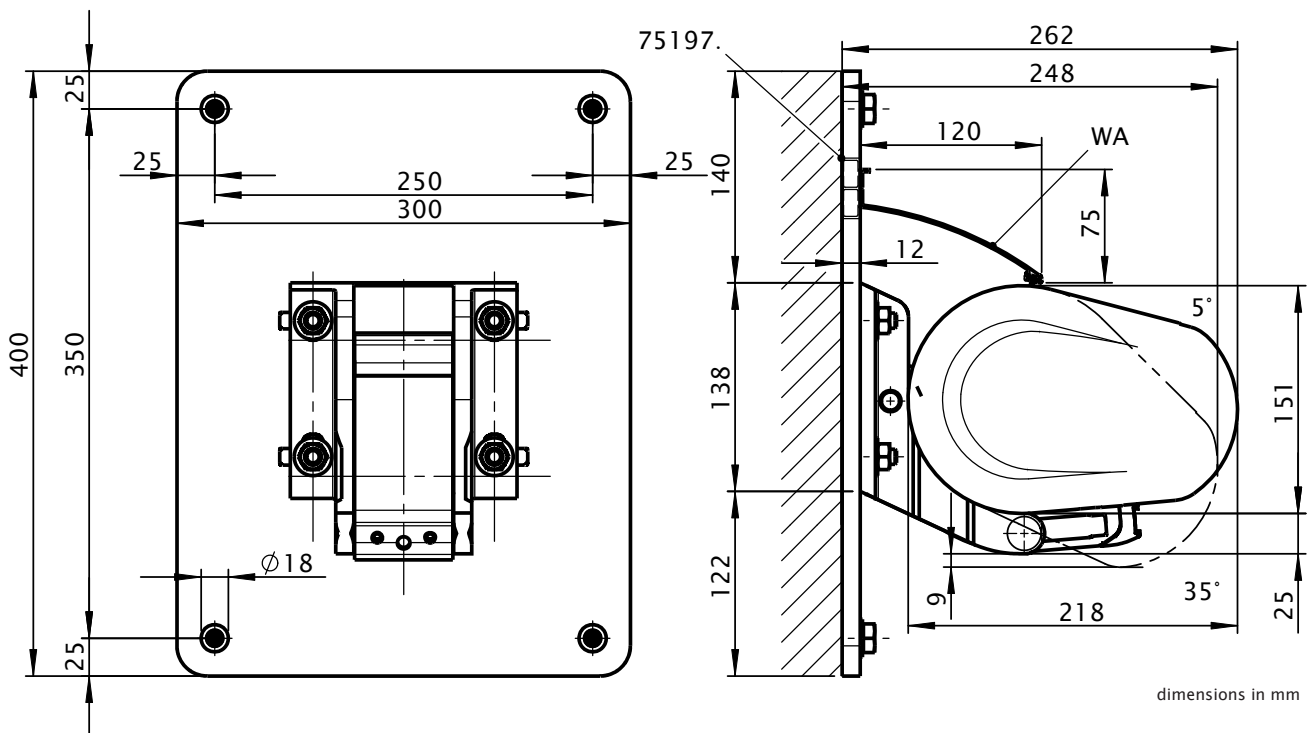

dimensions in mm

markilux 5010

Face fixture with shadeplus

Pull-out force [N=Newton] per fixture point according to EN 13561, wind resistance class 2

H [cm]	compression-proof substrate										non compression-proof substrate									
	M [cm]										M [cm]									
	250	300	350	400	450	500	550	600	650	700	250	300	350	400	450	500	550	600	650	700
	FB [N]										FB [N]									
150	818	958	1098	1239	1379	1519	1659	1800	1940	1579	936	1097	1257	1418	1578	1739	1899	2060	2220	1807
200	1251	1457	1663	1869	2074	2280	2486	2692	2898	2510	1432	1667	1903	2139	2374	2610	2845	3081	3316	2873
250	---	1989	2270	2551	2831	3112	3393	3674	4291	3777	---	2276	2598	2919	3240	3562	3883	4205	4911	4322
300	---	---	2954	3319	3684	4049	4822	---	---	4994	---	---	3380	3798	4216	4634	5519	---	---	5715
HT BHT	2 150 mm			3 150 mm			4 150 mm				2 150 mm			3 150 mm			4 150 mm			
BM	8			12			16				8			12			16			

The pull-out force refers to the vertical centre to centre measurement between the fixture points of 90 mm. If this measurement is reduced, the pull-out force increases by 2% in the case of **compression-proof** substrates and by 19% in the case of **non-compression-proof** substrates.

- M = overall awning width
- H = extension
- FB = pull-out force per fixing point
- HT | BHT = bracket quantity | width
- BM = no. of fixing points
- WA = wall sealing profile

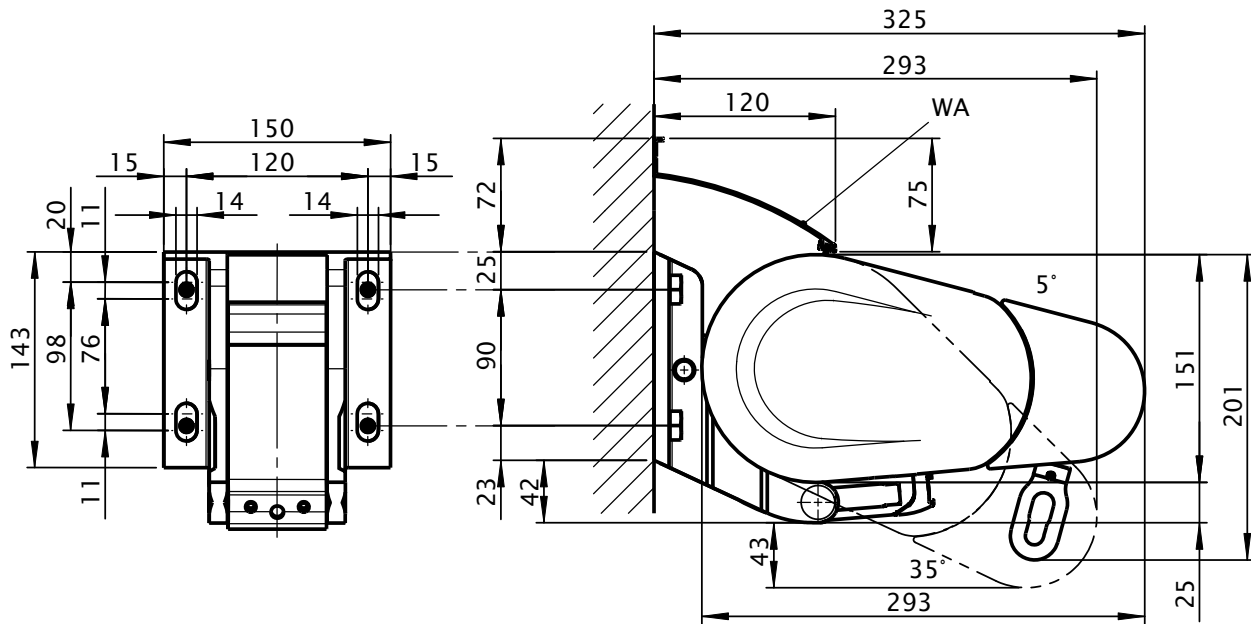

dimensions in mm

Face fixture with shadeplus and spreader plate A

Pull-out force [N=Newton] per fixture point according to EN 13561, wind resistance class 2

H [cm]	compression-proof substrate										non compression-proof substrate									
	M [cm]										M [cm]									
	250	300	350	400	450	500	550	600	650	700	250	300	350	400	450	500	550	600	650	700
	FB [N]										FB [N]									
150	394	462	529	597	664	732	800	867	935	738	560	656	752	848	944	1040	1136	1232	1328	1048
200	602	701	800	899	997	1096	1195	1294	1393	1161	855	996	1136	1277	1417	1558	1699	1839	1980	1650
250	---	955	1090	1225	1360	1494	1629	1764	2060	1749	---	1357	1549	1740	1932	2123	2315	2507	2928	2485
300	---	---	1417	1592	1767	1942	2313	---	---	2309	---	---	2014	2262	2511	2760	3288	---	---	3282
HT BHT	2 150 mm				3 150 mm				4 150 mm		2 150 mm				3 150 mm				4 150 mm	
BP	2				2				3		2				2				3	
DP	---				1				1		---				1				1	
BM	16				20				28		16				20				28	

The pull-out force refers to the vertical centre to centre measurement between the fixture points of 76 mm. In the case of spreader plates a washer conforming to DIN 9021 must be used.

- M = overall awning width
- H = extension
- FB = pull-out force per fixing point
- HT | BHT = bracket quantity | width
- BP = no. of spreader plates
- DP = no. of spacer plates
- BM = no. of fixing points
- WA = wall sealing profile
- 75197.: stand-off strip for wall sealing profile

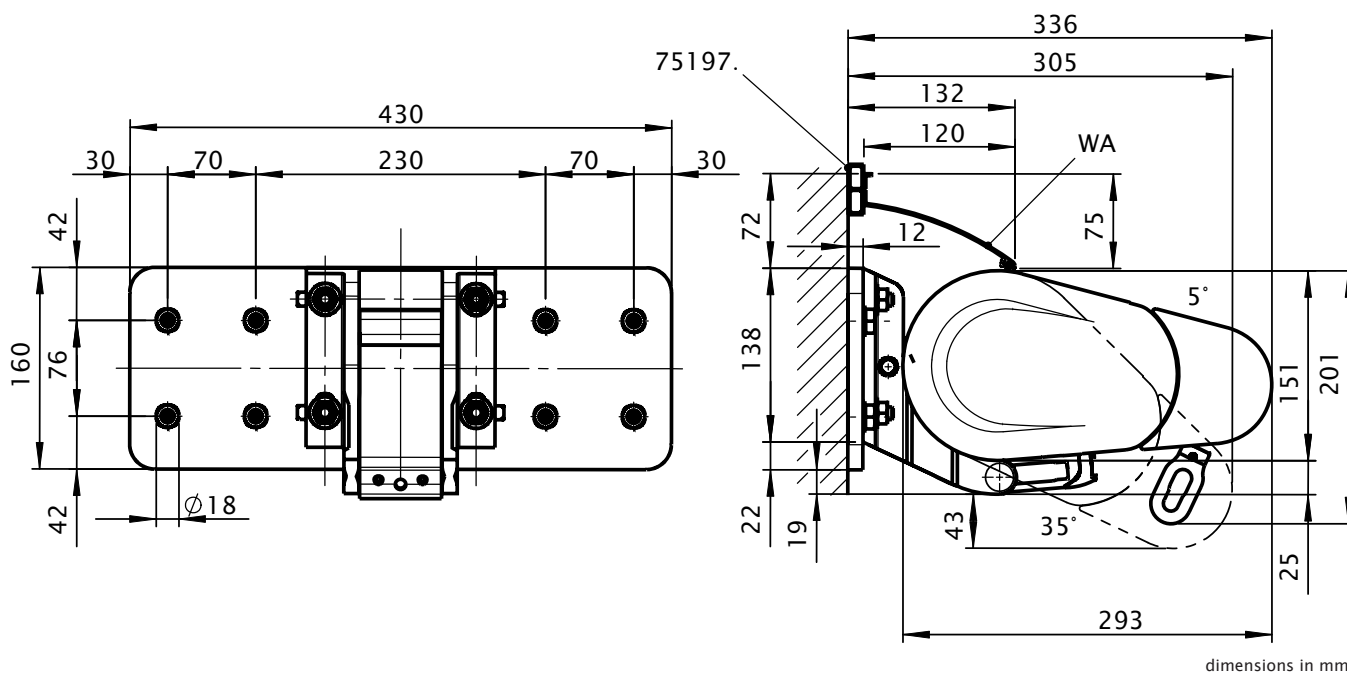

dimensions in mm

markilux 5010

Face fixture with shadeplus and spreader plate B

Pull-out force [N=Newton] per fixture point according to EN 13561, wind resistance class 2

H [cm]	compression-proof substrate										non compression-proof substrate									
	M [cm]										M [cm]									
	250	300	350	400	450	500	550	600	650	700	250	300	350	400	450	500	550	600	650	700
	FB [N]										FB [N]									
150	233	273	313	353	393	433	473	513	553	437	243	285	327	368	410	452	493	535	577	455
200	356	415	473	532	590	649	707	766	824	687	371	432	493	555	616	677	738	799	860	716
250	---	565	645	725	805	884	964	1044	1219	1035	---	589	673	756	839	922	1005	1089	1272	1079
300	---	---	839	942	1046	1149	1369	---	---	1367	---	---	874	983	1091	1199	1428	---	---	1425
HT BHT	2 150 mm			3 150 mm				4 150 mm			2 150 mm			3 150 mm				4 150 mm		
BP	2			2				3			2			2				3		
DP	---			1				1			---			1				1		
BM	8			12				16			8			12				16		

The pull-out force refers to the vertical centre to centre measurement between the fixture points of 350 mm. In the case of spreader plates a washer conforming to DIN 9021 must be used.

M = overall awning width
H = extension
FB = pull-out force per fixing point
HT | BHT = bracket quantity | width
BP = no. of spreader plates
DP = no. of spacer plates
BM = no. of fixing points
75197.: stand-off strip for wall sealing profile

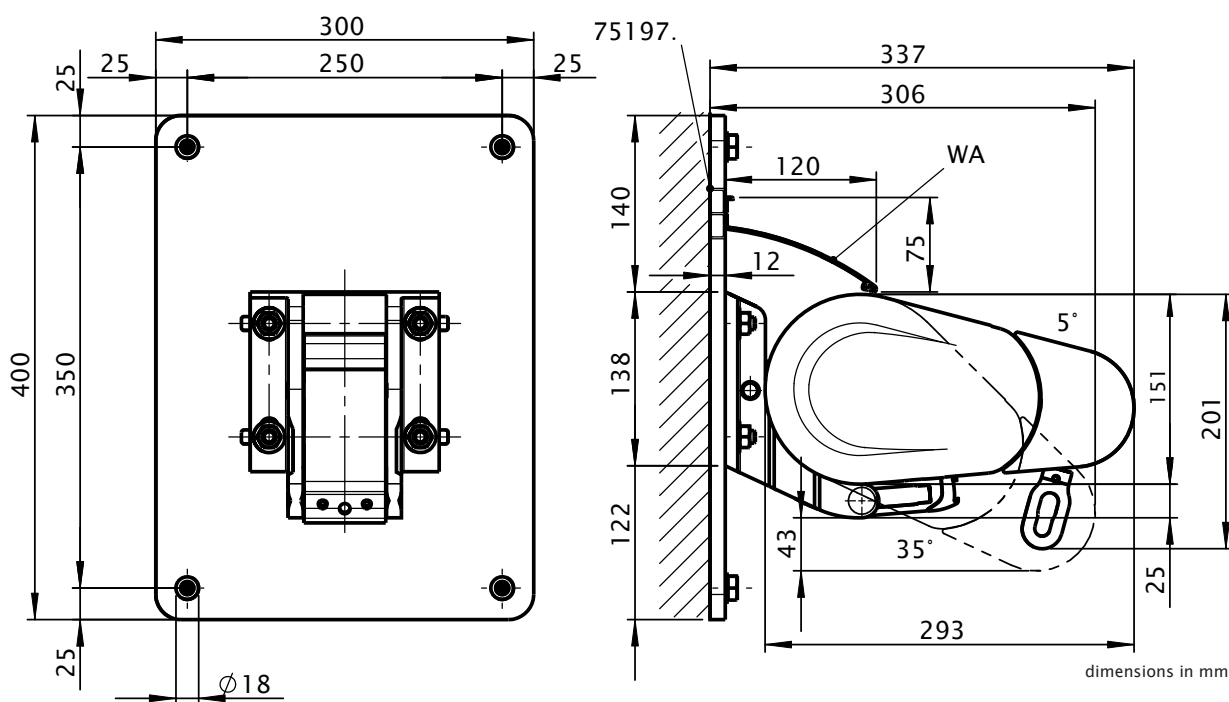

dimensions in mm

Top fixture

Pull-out force [N=Newton] per fixture point according to EN 13561, wind resistance class 2

H [cm]	compression-proof substrate										non compression-proof substrate									
	M [cm]										M [cm]									
	250	300	350	400	450	500	550	600	650	700	250	300	350	400	450	500	550	600	650	700
	FB [N]										FB [N]									
150	463	537	611	685	759	833	908	982	1056	916	479	555	632	709	785	862	938	1015	1091	945
200	724	833	943	1052	1162	1271	1381	1491	1600	1445	750	864	977	1090	1204	1317	1431	1544	1658	1496
250	---	1156	1308	1461	1613	1766	1918	2070	2489	2252	---	1199	1357	1515	1673	1831	1989	2147	2582	2335
300	---	---	1734	1937	2140	2343	2869	3102	3335	3025	---	---	1800	2011	2221	2432	2978	3220	3462	3139
350	---	---	---	2557	2818	3477	3779	4081	3849	4081	---	---	---	2656	2926	3611	3925	4238	3997	4237
400	---	---	---	---	3974	4354	4733	---	---	5114	---	---	---	---	4129	4523	4917	---	---	5311
HT BHT	2 135 mm				3 135 mm				4 135 mm		2 135 mm				3 135 mm				4 135 mm	
BM	6				9				12		6				9				12	

The pull-out force refers to the horizontal centre to centre measurement between the fixture points of 125 mm.

M = overall awning width
H = extension
FB = pull-out force per fixing point
HT | BHT = bracket quantity | width
BM = no. of fixing points

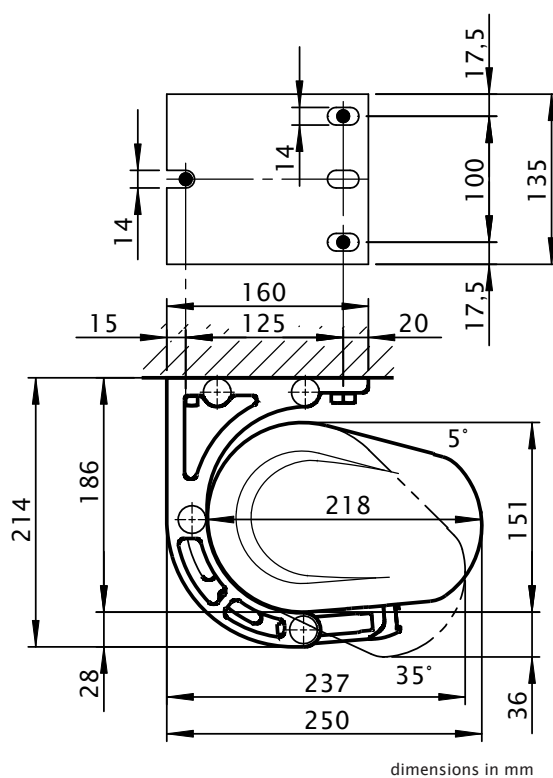

markilux 5010

Top fixture with shadeplus

Pull-out force [N=Newton] per fixture point according to EN 13561, wind resistance class 2

H [cm]	compression-proof substrate										non compression-proof substrate									
	M [cm]										M [cm]									
	250	300	350	400	450	500	550	600	650	700	250	300	350	400	450	500	550	600	650	700
	FB [N]										FB [N]									
150	711	834	958	1081	1205	1329	1452	1576	1699	1426	736	865	993	1121	1249	1377	1505	1633	1761	1476
200	1054	1229	1405	1581	1756	1932	2107	2283	2459	2164	1093	1276	1458	1640	1822	2004	2186	2368	2550	2244
250	---	1651	1886	2121	2356	2591	2826	3061	3562	3167	---	1714	1958	2202	2446	2690	2933	3177	3698	3287
300	---	---	2428	2730	3031	3333	3958	---	---	4132	---	---	2521	2835	3148	3462	4111	---	---	4290
HT BHT	2 135 mm			3 135 mm			4 135 mm				2 135 mm			3 135 mm			4 135 mm			
BM	6			9			12				6			9			12			

The pull-out force refers to the horizontal centre to centre measurement between the fixture points of 125 mm.

M = overall awning width
 H = extension
 FB = pull-out force per fixing point
 HT | BHT = bracket quantity | width
 BM = no. of fixing points

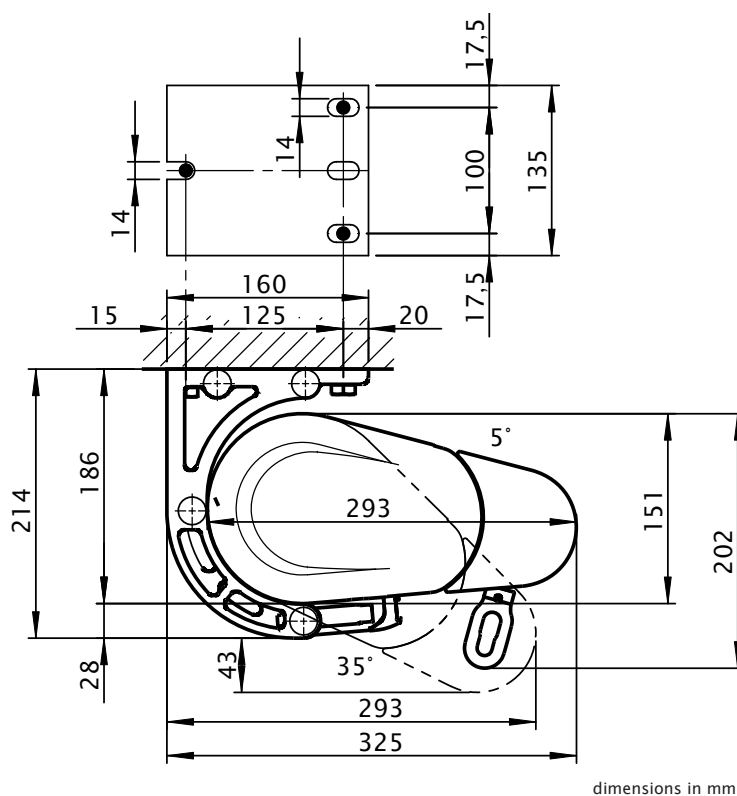

Eaves/Roof timber fixture

Pull-out force [N=Newton] for the fixture bracket next to the arm according to EN 13561, wind resistance class 2

H [cm]	Torque										shear force									
	M [cm]										M [cm]									
	250	300	350	400	450	500	550	600	650	700	250	300	350	400	450	500	550	600	650	700
	Md [Nm]										FS [N]									
150	104	120	136	152	168	184	200	216	232	193	1282	1485	1688	1891	2094	2297	2499	2702	2905	2490
200	172	197	222	248	273	298	323	349	374	330	2035	2340	2646	2951	3257	3562	3867	4173	4478	4018
250	---	281	317	354	390	427	463	499	605	540	---	3272	3701	4131	4560	4989	5419	5848	7046	6351
300	---	---	428	478	527	577	710	767	825	741	---	---	4933	5508	6082	6657	8165	8828	9490	8584
350	---	---	---	639	703	872	947	1022	959	1015	---	---	---	7299	8040	9934	10795	11655	10976	11633
400	---	---	---	---	1004	1099	1195	---	---	1284	---	---	---	---	11381	12466	13552	---	---	14617
HT	2				3				4		2				3				4	
BM	8				12				16		8				12				16	

The shear force are calculated from 2 fixture points per bracket, because depending on the roof pitch it cannot be guaranteed that 4 fixture points per bracket can be used.

- M = overall awning width
- H = extension
- Md = torque value for the bracket next to the arm
- FS = shear force
- HT = bracket
- BM = no. of fixing points

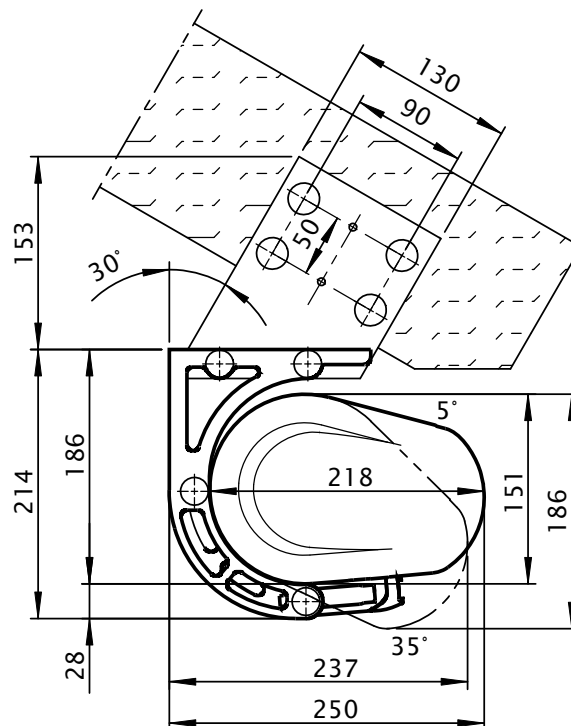

dimensions in mm

markilux 5010

Eaves fixture with additional plate

Pull-out force [N=Newton] for the fixture bracket next to the arm according to EN 13561, wind resistance class 2

H [cm]	Torque										shear force									
	M [cm]										M [cm]									
	250	300	350	400	450	500	550	600	650	700	250	300	350	400	450	500	550	600	650	700
	Md [Nm]										FS [N]									
150	104	120	136	152	168	184	200	216	232	193	646	751	856	961	1066	1171	1276	1381	1486	1313
200	172	197	222	248	273	298	323	349	374	330	984	1136	1287	1438	1589	1740	1892	2043	2194	2001
250	---	281	317	354	390	427	463	499	605	540	---	1555	1762	1969	2176	2383	2590	2797	3350	3050
300	---	---	428	478	527	577	710	767	825	741	---	---	2316	2588	2861	3133	3826	4137	4449	4055
350	---	---	---	639	703	872	947	1022	959	1015	---	---	---	3394	3742	4608	5009	5410	5118	5427
400	---	---	---	---	1004	1099	1195	---	---	1284	---	---	---	---	5245	5747	6250	---	---	6770
HT	2			3				4			2			3				4		
BM	4			6				8			4			6				8		

By using the additional flat plate, the shear force is reduced in comparison with conventional eaves fixture.

- M = overall awning width
- H = extension
- Md = torque value for the bracket next to the arm
- FS = shear force
- HT = bracket
- BM = no. of fixing points

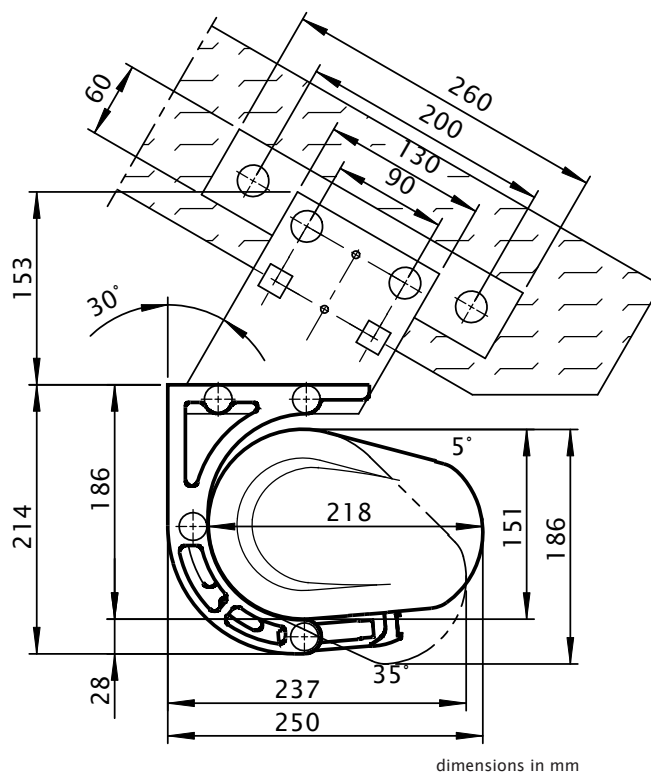

dimensions in mm

bottom fixture

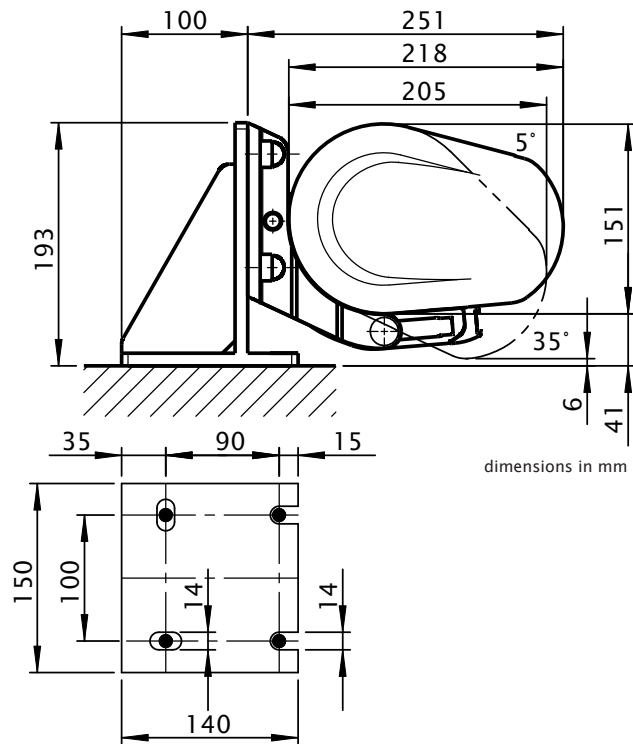

dimensions at pitches of 38° to 65°

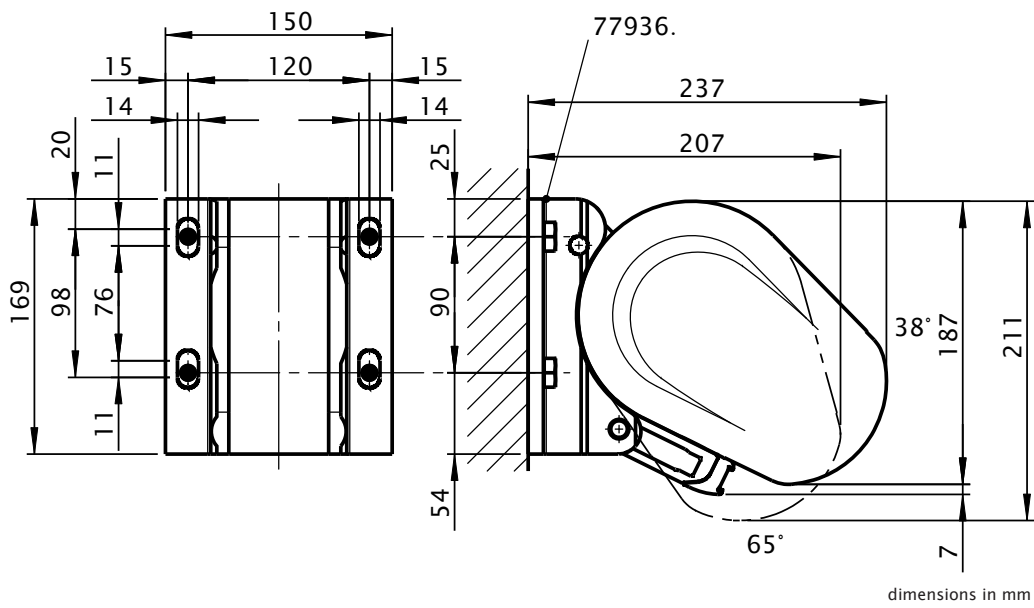

markilux 5010

Bracket range for awnings with 2 folding arms

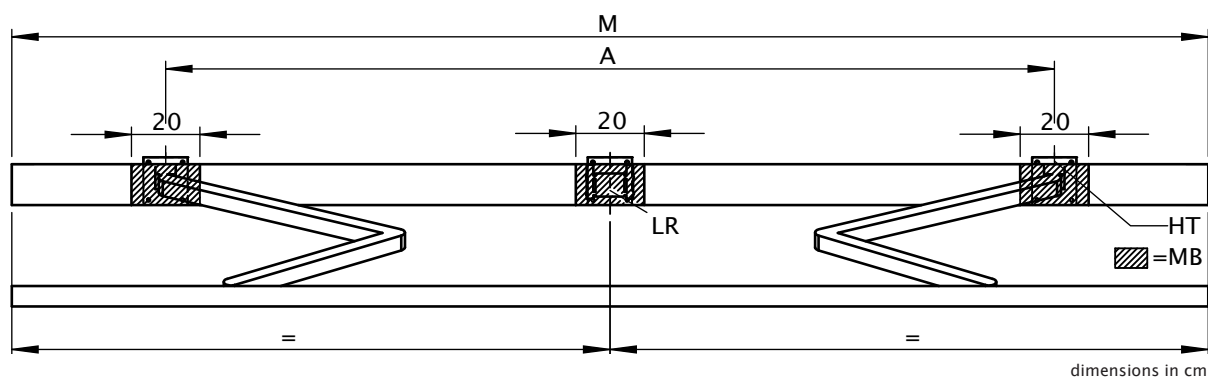

M [cm]	SB ZB	250 250	300 251-300	350 301-350	400 351-400	450 401-450	500 451-500	550 501-550	600 551-600	650 601-650
		A [cm]								
H [cm]	150	190 ■	230	270	300	340	380	440	490	510
	200	220 ▲	230 ■	270	300	340	380	440	490	510
	250	---	270 ▲	270 ■	300	340	390	440	490	510
	300	---	---	320 ▲	340 ■	340	390	440	490	510 ▲
	350	---	---	---	370 ▲	390 ■	390	440	490	---
	400	---	---	---	---	420 ▲	435 ▲	440 ■	---	---
W	HT BHT	150 mm	2			3				
DE/DA	HT BHT	135 mm	2			3				

dimensions in cm

▲ = coupled units not available with junction roller

■ = coupled units are only available with junction roller in the standard widths, in other widths on request

M = overall awning width

A = arm position

HT = bracket

MB = range for bracket fixture

LR = Rolltex bearing with bracket is always situated under the central seam (only at an extension of 400 cm)

H = extension

SB = standard width

ZB = intermediate width

W = face fixture

DE/DA = top fixture and eaves fixture

HT | BHT = bracket quantity | width

If the brackets cannot be positioned in accordance with this table, make sure the actual measurements are noted on the order form!

Bracket range for awnings with 3 folding arms

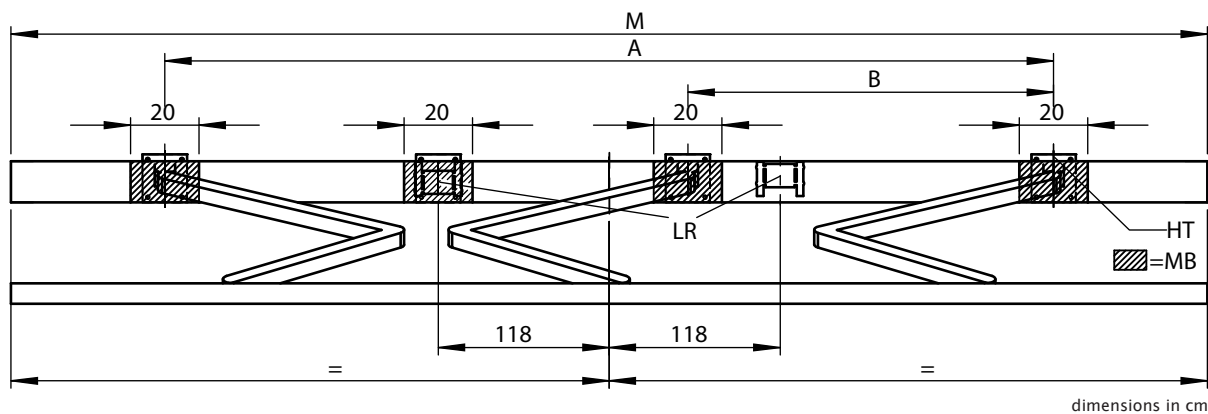

M [cm]	SB ZB	650				700								
		601-650		650		651-674		675-700		651-692		693-700		
H [cm]		A [cm]	B [cm]	A [cm]	B [cm]	A [cm]	B [cm]	A [cm]	B [cm]	A [cm]	B [cm]	A [cm]	B [cm]	
	150	---	---	---	---	570	265	590	265	---	---	---	---	
	200	---	---	---	---	570	240	590	240	---	---	---	---	
	250	---	---	---	---	570	230	590	230	---	---	---	---	
	300	---	570 ▲	230 ▲	---	---	570	230	590	230	---	---	---	---
	350	---	---	---	620 ▲	220 ▲	---	---	---	---	620 ▲	225 ▲	620	225
400	---	---	---	---	---	---	---	---	---	---	---	670 •	234 •	
W	HT BHT	150mm	4											
DE/DA	HT BHT	135mm	4											

dimensions in cm

▲ = coupled units not available with junction roller

• = no coupled units possible

M = overall awning width

A = arm position

B = arm position

HT = bracket

MB = range for bracket fixture

LR = Rolltex bearing with bracket is always situated under the central seam (depends on the width)

H = extension

SB = standard width

ZB = intermediate width

W = face fixture

DE/DA = top fixture and eaves fixture

HT | BHT = bracket quantity | width

If the brackets cannot be positioned in accordance with this table, make sure the actual measurements are noted on the order form!