

safe · timeless · beautiful



markilux 1500

Unique in design and technology



markilux 1500

Unique in design and technology

- design features**
- Shaped by well-known designers, given the IF Design Award for excellent design.
 - A semi-cassette folding-arm awning. The dynamically rounded coverboard gives the awning the appearance of being fully cassetted.
 - The possibility of mixing and matching the colour of the cassette with that of the end caps gives you the option of making your markilux awning your very own.
 - Elegant and robust front profile made of aluminium with valance slot.
 - for long-lasting attractiveness the awning has been powder coated.

- technical highlights**
- Attractive ovoid folding arms with unique gas piston technology ensure a taut cover in every position whether partially or fully extended.
 - Folding arms with drop-forged aluminium moving components and Teflon-coated bronze bushes, which provide superior robustness and longevity.
 - High lateral awning stability by virtue of the longer upper and shorter lower arm.
 - Coverboard with integrated brush so that larger pieces of debris cannot be drawn into the awning.
 - Sturdy, round steel torque bar, 50 mm Ø, to prevent twist and deflection.

- optional accessories**
- Hard-wired motor drive (optionally with automatic controls) for simple, relaxed operation.
 - Radio-controlled motor with handheld transmitter for ease of operation - and ergonomically crafted for ease of use.
 - The shadeplus creates an additional room on the patio. Protection from sun, wind and inquisitive glances in one.
 - Awning available in non-standard RAL colours
 - An easily connected sun and wind sensor provides intelligent control options and essential protection.

· Beautifully crafted brackets; Design down to the last detail · Awning covers made from acrylic fabric or sunsilk snc with self-cleaning effect · The panel joints of the awning cover are ultrasonically bonded to give a better appearance without bothersome stitching · Manual operation includes a markilux stainless steel winding handle - quality to get to grips with · The 85 mm roller tube ensures the highest rigidity and the best possible cover winding characteristics even at the largest widths · Fixture brackets are made of extruded aluminium · Simply pitch adjustment via the bracket without necessitating readjustment of the front profile · At larger widths one or more rolltex bearings support the roller tube · A servo-assisted gearbox facilitates manual operation · Awnings more than 660 cm wide can be supplied as coupled units · An optional wall sealing profile covers the gap between wall and awning · Available with a valance

Folding-arm awning markilux 1500



simple pitch adjustment

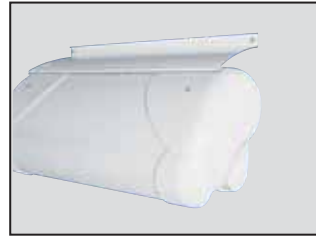

wall sealing profile (optional)



side view with awning closed, face fixture



Side view of top-fixed awning with shadeplus (optional) retracted



folding arm with gas piston

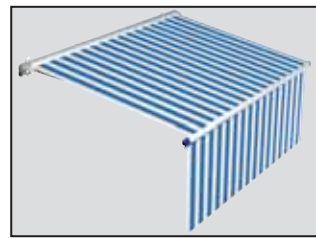

Shadeplus (optional)



Standard RAL colours:



standard:

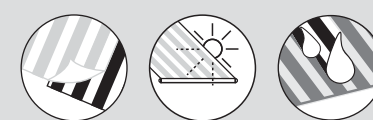

optional accessories:



safe · timeless · beautiful

markilux 1500



Choice of colours

frame colours	End caps
traffic white RAL 9016	traffic white RAL 9016
metallic aluminium RAL 9006	metallic aluminium RAL 9006
light ivory RAL 1015	light ivory RAL 1015
grey brown RAL 8019	grey brown RAL 8019
	yellow
	ruby red
	blue
	black



End caps
Colour combination 1



End caps
Colour combination 9



End caps
Colour combination 3



End caps
Colour combination 3



End caps
Colour combination 10

markilux 1500

Unique in design and technology

markilux 1500 Lounge

frame colours	End caps
Nano off-white textured finish 5233	Nano off-white textured finish 5233
Nano stone grey metallic 5215	Nano stone grey metallic 5215
Nano anthracite metallic 5204	Nano anthracite metallic 5204
	Polished chrome



dimensions and configuration options

extension	Overall blind width									minimum width motor operation ¹⁰⁾	minimum width manual operation ¹¹⁾
	260 193-260	310 261-310	360 311-360	410 361-410	460 411-460	510 461-510	560 511-560	610 561-610	660 611-660	standard arms	standard arms
150										193	196
200	28)									243	246
250		28)								293	296
300			28)							343	346
350				28)						393	396

dimensions in cm

10) the dimensions are only valid for fixture without spreader plates (2 folding arms).

28) Please note the minimum widths!

 = available, 2 folding arms

 = available, 2 folding arms, 1 Rolltex bearing

operation type	
manual operation with st. steel winding handle	●
Servo-assisted operation	●
radio-controlled motor	○
motor	○
Shadeplus	
manual operation	○
radio-controlled motor	○
motor	○
Lighting	
Halogen Spotlights	-
Fluorescent lighting	-
covers	
acrylic 34 (fabric series 341xx-347xx)	●
sunsilk SNC (fabric series 324xx/329xx)	●
signature (fabric series 369xx)	●
transilk FR (fabric series 319xx)	-
transolair (fabric series 339xx)	-
widely woven acrylic (fabric series 349xx)	○ ¹
perla FR (fabric series 374xx/379xx)	○
Soltis 92	○ ²
PVC fabric	○ ²
miscellaneous	
Coverboard	-
Sytem coverboard	-
wall sealing profile	○ ³
Pitch adjustment gear	-
Insertable side blind	○
sun and wind sensor	○
Valance	○
Infrared heater	○
Vibrabox / Sunis sun sensor	○
Coupled units (please refer to fixture)	
coupled unit 2 fields	○
coupled unit 3 fields	-
junction roller	○
one-piece cover (on request)	-

● = fitted as standard

○ = optional accessory

- = not available

○¹ = widely woven fabric up to a max. extension of 300 cm; not possible in those dimensions that require a rolltex bearing○² = PVC/Soltis 92 covers available up to a max. width of 610 cm and a max. arm length of 250 cm.○³ = wall sealing profile effective up to an awning pitch of 20°

Definition of extension: The extension is measured with the awning extended at a pitch of approx. 15° from the wall over the cover to the leading edge of the front profile. The extension tolerance is - 40mm / + 40mm

In the case of manual operation, assume approx. 16 winding handle revolutions per metre of awning extension.

Extension when using a motor takes approximately 12 seconds per metre.

Definition of shadeplus drop: The shadeplus drop is measured from the bottom edge of the shadeplus profile to the bottom edge of the valance profile. Because of tolerances in fabric thicknesses the drop may be shorter by up to 5 cm.

A manual shadeplus is available in the standard drops of 150 cm and 210 cm (210 cm only in transilk (319xx), transolair (339xx), widely woven fabrics (349xx) seamless or Soltis 92. Shadeplus covers with a drop greater than 170 cm in Soltis 92 will be made with a horizontal seam).

A motorised shadeplus is available in the standard drops of 100 cm (only in transolair (339xx) and seamless plain sunsilk or acrylic fabrics) and 120 cm (only in seamless Soltis 92).









A shadeplus is not possible with PVC covers.

Coupled folding-arm awnings are available up to a max. of 2 single units positioned next to one another and only operated by motor.

Optionally available with junction roller. Pattern repeat mismatches are possible in the case of junction roller covers.





except when the extension is the maximum for the width of each awning. (see also arm separation table)

If coupled awnings are to be fitted into a recess or reveal the overall width of the coupled blind or awning must be at least 6 cm less than the width of the opening to allow the blind/awning to be coupled. Make a special note if the awning is to be fitted into a recess/reveal and note the reveal width separately.

frame colours		
	RAL 9016 traffic white	●
	RAL 8019 grey brown	●
	RAL 9006 metallic aluminium	●
	RAL 1015 light ivory	●
	5204 Nano anthracite metallic 5204 (Lounge)	○
	5215 Nano stone grey metallic 5215 (Lounge)	○
	5233 Nano off-white textured finish (Lounge)	○
	non-standard RAL colour	○

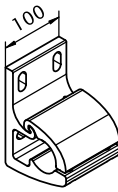
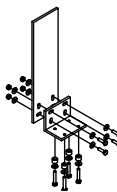
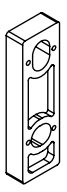
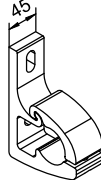
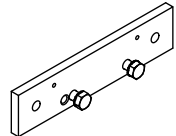
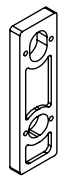
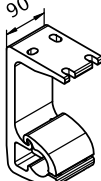
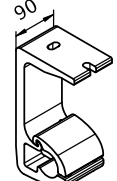
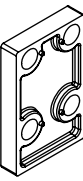
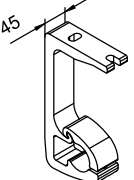
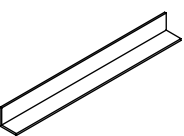

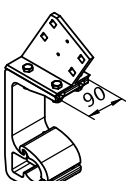
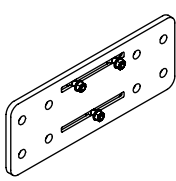
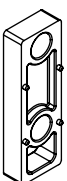
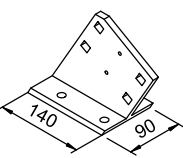
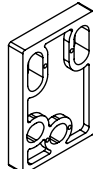
markilux 1500

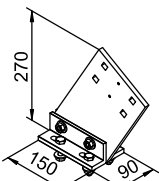
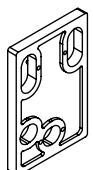
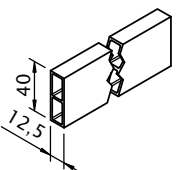
fixings and accessories

 70867.	Face fixture bracket assembly 100mm	 716620	Angle and fixture plate for eaves fixture machine finish	 718251	Spacer plate for face fixture 45x150x20mm N.B! stack to a max. of 200 mm
 71813.	Face fixture bracket assembly 45mm	 75383.	Additional eaves fixture plate 60x260x12mm	 71826.	Spacer plate for face fixture 45x150x12mm
 70868.	Top fixture bracket assembly 90mm	 70869.	Top fixture bracket assembly assembly for central fixture	 716311	Spacer plate for top fixture 90x140x20mm N.B! stack to a max. of 200 mm
 71818.	Top fixture bracket assembly 45mm	 79380.	Angled profile for eaves fixtures 100x100mm available by the metre, undrilled	 716411	Spacer plate for top fixture 90x140x12mm
 70871.	Eaves fixture bracket assembly 90mm complete set	 75326.	Component assembly spreader plate A 160x430x12mm	 716261	Spacer plate for top fixture 45x140x20mm N.B! stack to a max. of 200 mm
 71612.	Eaves fixture bracket 140mm	 718231	Spacer plate for face fixture 100x150x20mm N.B! stack to a max. of 200 mm	 716371	Spacer plate for top fixture 45x140x12mm
 71659.	Eaves fixture bracket assembly 270mm	 718241	Spacer plate for face fixture 100x150x12mm	 751971	stand-off strip for wall sealing profile available by the metre Fixture example, see face fixture with wall sealing profile

. = Please insert the RAL No. (please refer to the section on "Coatings")

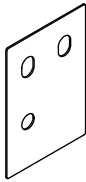
fixings and accessories

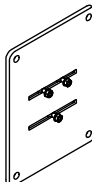
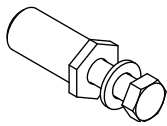
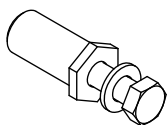
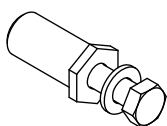
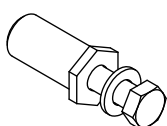
	Cover plate for external insulation
71833.	140x200x2mm
	Cover plate for external insulation
71834.	85x200x2mm
	Component assembly spreader plate B
75325.	300x400x12mm
	Reduction assembly M 16 - M 12 / SW 27
753891	50mm length (please refer to "Technical Information")
	Reduction assembly M 10 - M 10 / SW 27
754901	50mm length (please refer to "Technical Information")
	Reduction assembly M 12 - M 10 / SW 27
754911	50mm length (please refer to "Technical Information")
	reducing bolt assembly M 16 - M 10 / SW 27
754921	50mm length (please refer to "Technical Information")

. = Please insert the RAL No.
(please refer to the section on "Coatings")

Face fixture with spreader plate A

Pull-out force [N=Newton] per fixture point according to EN 13561, wind resistance class 2

H [cm]	compression-proof substrate									non compression-proof substrate								
	M [cm]									M [cm]								
	260	310	360	410	460	510	560	610	660	260	310	360	410	460	510	560	610	660
	FB [N]									FB [N]								
150	272	308	345	381	418	455	491	528	565	386	438	490	542	594	646	698	750	802
200	426	484	541	599	657	715	772	830	888	605	687	769	851	933	1016	1098	1180	1262
250	---	693	776	859	943	1026	1110	1193	1438	---	984	1103	1221	1340	1458	1577	1696	2044
300	---	---	1054	1168	1282	1395	1704	1836	1968	---	---	1498	1660	1821	1983	2422	2610	2797
350	---	---	---	1518	1883	2056	2229	2402	---	---	---	---	2157	2676	2922	3167	3413	---
HT BHT	2 100 mm				2 100 mm					2 100 mm				2 100 mm				
	---				1 45 mm					---				1 45 mm				
BP	2				2					2				2				
DP	---				1					---				1				
BM	16				18					16				18				

The pull-out force refers to the vertical centre to centre measurement between the fixture points of 76 mm. In the case of spreader plates a washer conforming to DIN 9021 must be used.

- M = overall awning width
- H = extension
- FB = pull-out force per fixing point
- HT | BHT = bracket quantity | width
- BP = no. of spreader plates
- DP = no. of spacer plates
- BM = no. of fixing points
- WA = wall sealing profile
- 75197.: stand-off strip for wall sealing profile

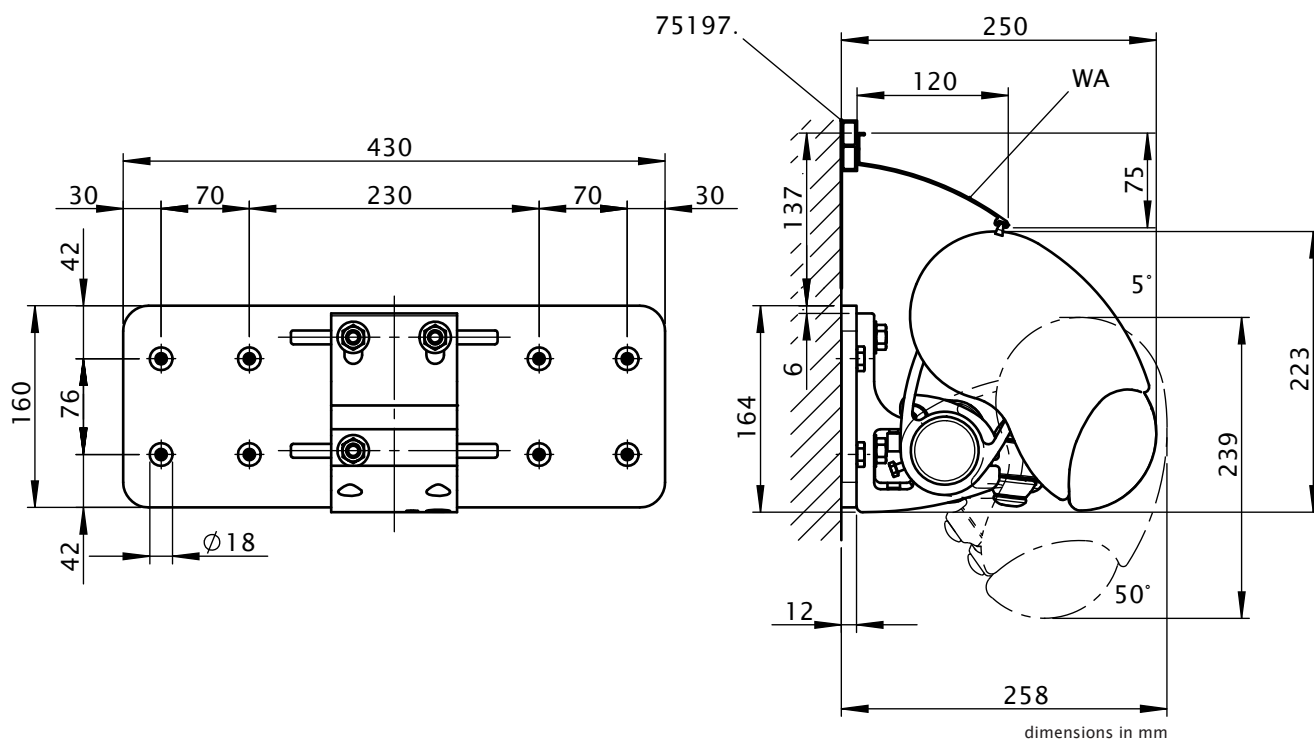

markilux 1500

Face fixture with spreader plate B

Pull-out force [N=Newton] per fixture point according to EN 13561, wind resistance class 2

compression-proof substrate										non compression-proof substrate									
H [cm]	M [cm]									M [cm]									
	260	310	360	410	460	510	560	610	660	260	310	360	410	460	510	560	610	660	
FB [N]										FB [N]									
150	161	182	204	226	247	269	291	312	334	168	190	213	235	258	281	303	326	348	
200	252	286	320	355	389	423	457	491	525	263	298	334	370	405	441	477	512	548	
250	---	410	459	509	558	607	657	706	851	---	427	479	530	582	633	685	736	888	
300	---	---	624	691	758	826	1009	1087	1165	---	---	651	721	791	861	1052	1133	1215	
350	---	---	---	898	1114	1217	1319	1421	---	---	---	---	937	1162	1269	1376	1482	---	
HT BHT	2 100 mm					2 100 mm				2 100 mm					2 100 mm				
	---					1 45 mm				---					1 45 mm				
BP	2					2				2					2				
DP	---					1				---					1				
BM	8					10				8					10				

The pull-out force refers to the vertical centre to centre measurement between the fixture points of 350 mm.
In the case of spreader plates a washer conforming to DIN 9021 must be used.

M = overall awning width
H = extension
FB = pull-out force per fixing point
HT | BHT = bracket quantity | width
BP = no. of spreader plates
DP = no. of spacer plates
BM = no. of fixing points

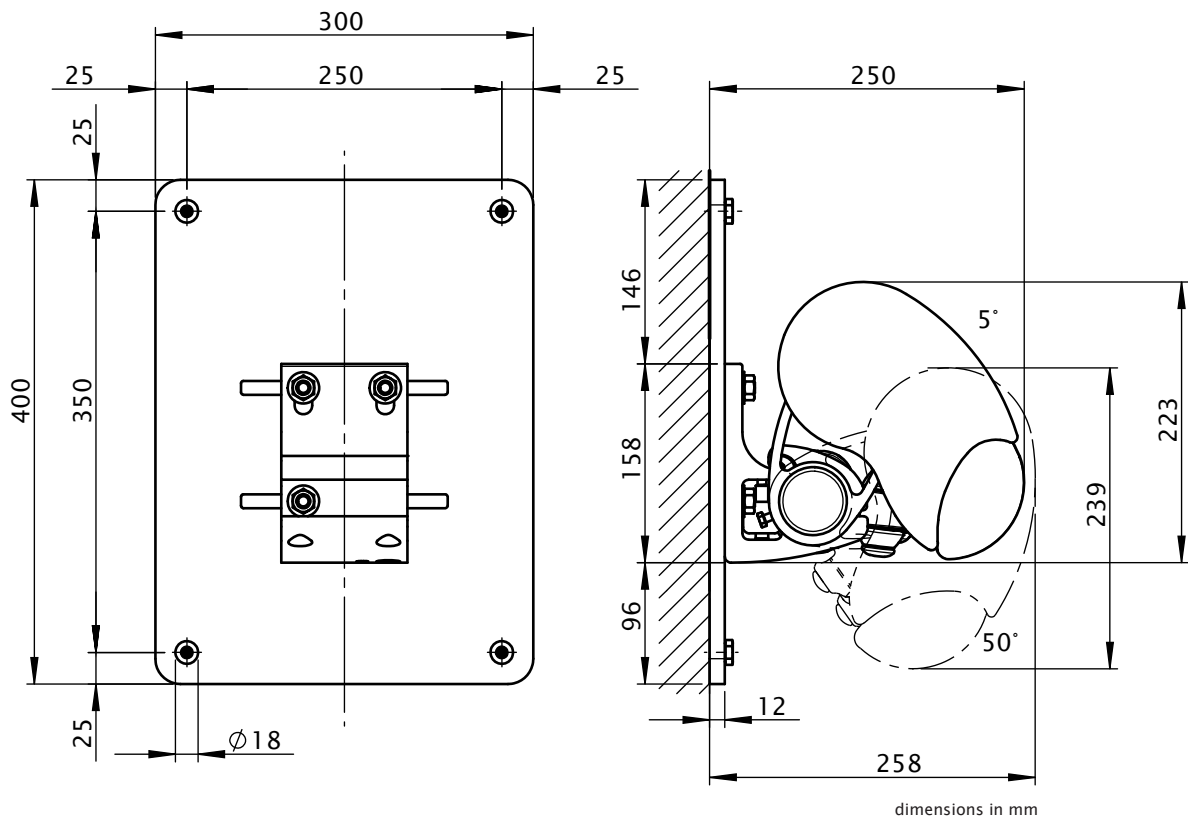

Face fixture with shadeplus

Pull-out force [N=Newton] per fixture point according to EN 13561, wind resistance class 2

H [cm]	compression-proof substrate									non compression-proof substrate								
	M [cm]									M [cm]								
	260	310	360	410	460	510	560	610	660	260	310	360	410	460	510	560	610	660
FB [N]																		
150	549	627	706	784	863	941	1020	1098	1177	750	857	965	1072	1179	1287	1394	1501	1608
200	844	965	1085	1206	1326	1446	1567	1687	1808	1154	1318	1483	1648	1812	1977	2141	2306	2471
250	---	1361	1531	1702	1872	2042	2213	2383	2834	---	1860	2093	2326	2558	2791	3024	3257	3874
300	---	---	2048	2276	2504	2732	3301	3561	3821	---	---	2799	3111	3422	3734	4512	4867	5223
350	---	---	---	2936	3608	3945	4282	4619	---	---	---	---	4013	4930	5391	5852	6312	---
HT BHT	2 100 mm				2 100 mm					2 100 mm				2 100 mm				
	---				1 45 mm					---				1 45 mm				
BM	6				8					6				8				

The pull-out force refers to the vertical centre to centre measurement between the fixture points of 90 mm. If this measurement is reduced, the pull-out force increases by 14% in the case of **compression-proof** substrates and by 19% in the case of **non-compression-proof** substrates. If the awning is fitted with two brackets per folding arm the pull-out force may be halved. Position the brackets to the left and right of the arm bearer.

- M = overall awning width
- H = extension
- FB = pull-out force per fixing point
- HT | BHT = bracket quantity | width
- BM = no. of fixing points
- WA = wall sealing profile

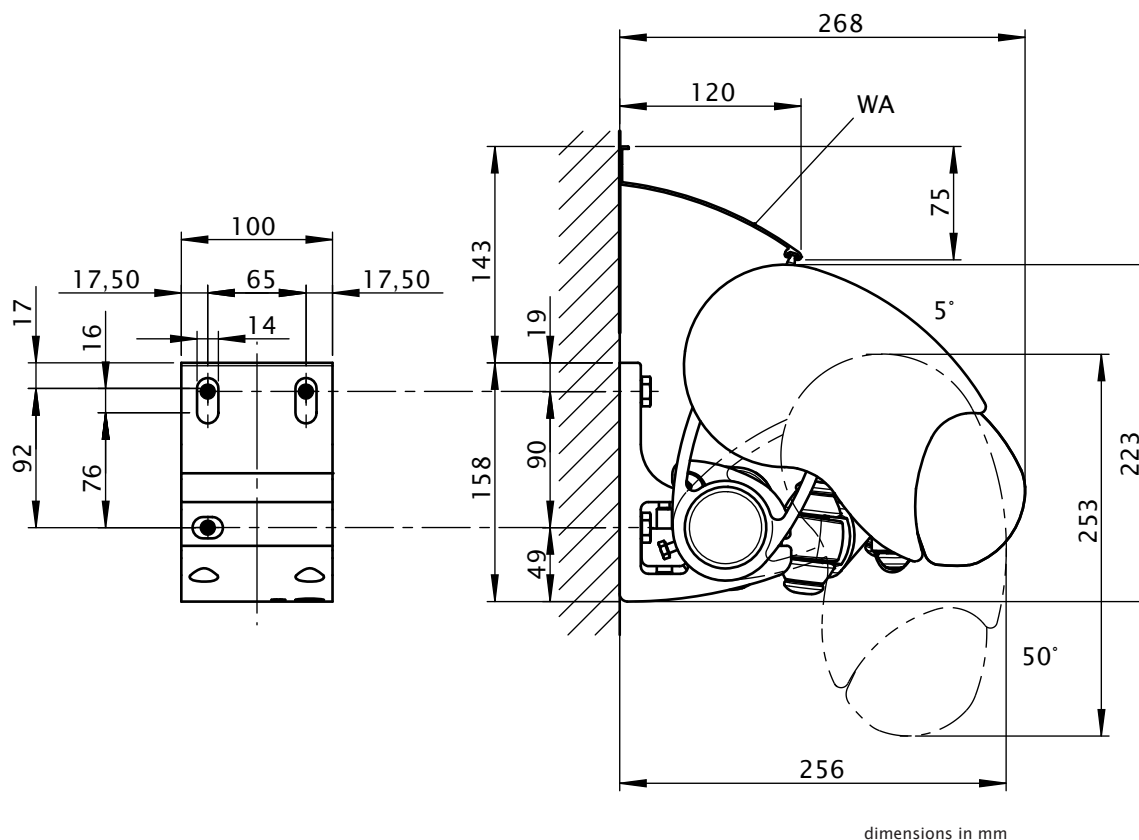

markilux 1500

Top fixture

Pull-out force [N=Newton] per fixture point according to EN 13561, wind resistance class 2

		compression-proof substrate									non compression-proof substrate								
		M [cm]									M [cm]								
		260	310	360	410	460	510	560	610	660	260	310	360	410	460	510	560	610	660
H [cm]		FB [N]									FB [N]								
150		617	704	791	878	965	1052	1138	1225	1312	789	900	1010	1120	1230	1340	1451	1561	1671
200		932	1063	1193	1323	1453	1584	1714	1844	1974	1203	1371	1538	1705	1872	2039	2206	2373	2540
250		---	1491	1674	1857	2039	2222	2405	2588	3100	---	1933	2169	2405	2641	2877	3113	3349	4017
300		---	---	2237	2482	2726	2971	3615	3897	4179	---	---	2908	3225	3542	3859	4701	5067	5433
350		---	---	---	3207	3965	4331	4698	5064	---	---	---	---	4177	5168	5645	6122	6599	---
HT BHT		2 90 mm				2 90 mm					2 90 mm				2 90 mm				
		---				1 45 mm					---				1 45 mm				
BM		8				10					8				10				

The pull-out force refers to the horizontal centre to centre separation of the fixture point of 80 mm. If the awning is fitted with two brackets per folding arm the pull-out force may be halved. Place the brackets directly left and right of the arm bearer.

M = overall awning width
 H = extension
 FB = pull-out force per fixing point
 HT | BHT = bracket quantity | width
 BM = no. of fixing points

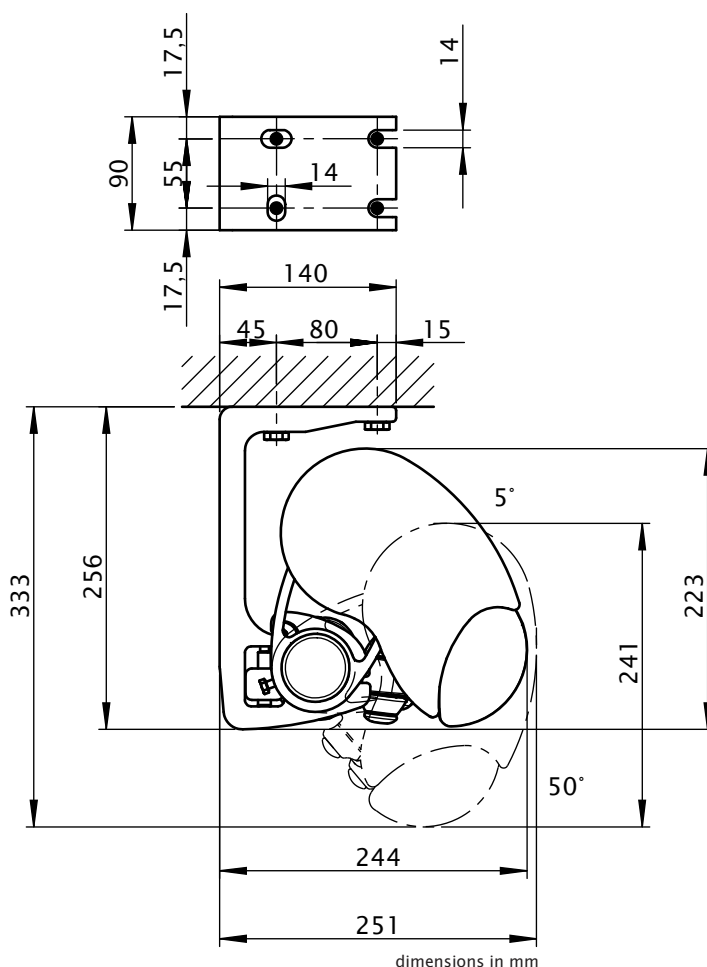

dimensions in mm

Top fixture with shadeplus

Pull-out force [N=Newton] per fixture point according to EN 13561, wind resistance class 2

H [cm]	compression-proof substrate									non compression-proof substrate								
	M [cm]									M [cm]								
	260	310	360	410	460	510	560	610	660	260	310	360	410	460	510	560	610	660
FB [N]																		
150	708	812	917	1021	1126	1230	1335	1439	1544	909	1042	1175	1308	1442	1575	1708	1841	1974
200	1054	1207	1361	1515	1668	1822	1976	2129	2283	1363	1561	1758	1956	2154	2351	2549	2747	2945
250	---	1672	1884	2096	2308	2520	2732	2944	3485	---	2170	2445	2719	2993	3268	3542	3816	4523
300	---	---	2497	2776	3056	3335	4015	4332	4649	---	---	3249	3612	3975	4338	5226	5638	6050
350	---	---	---	3542	4341	4748	5156	5563	---	---	---	---	4617	5662	6192	6723	7254	---
HT BHT	2 90 mm				2 90 mm					2 90 mm				2 90 mm				
	---				1 45 mm					---				1 45 mm				
BM	8				10					8				10				

The pull-out force refers to the horizontal centre to centre separation of the fixture point of 80 mm. If the awning is fitted with two brackets per folding arm the pull-out force may be halved. Place the brackets directly left and right of the arm bearer.

M = overall awning width
 H = extension
 FB = pull-out force per fixing point
 HT | BHT = bracket quantity | width
 BM = no. of fixing points

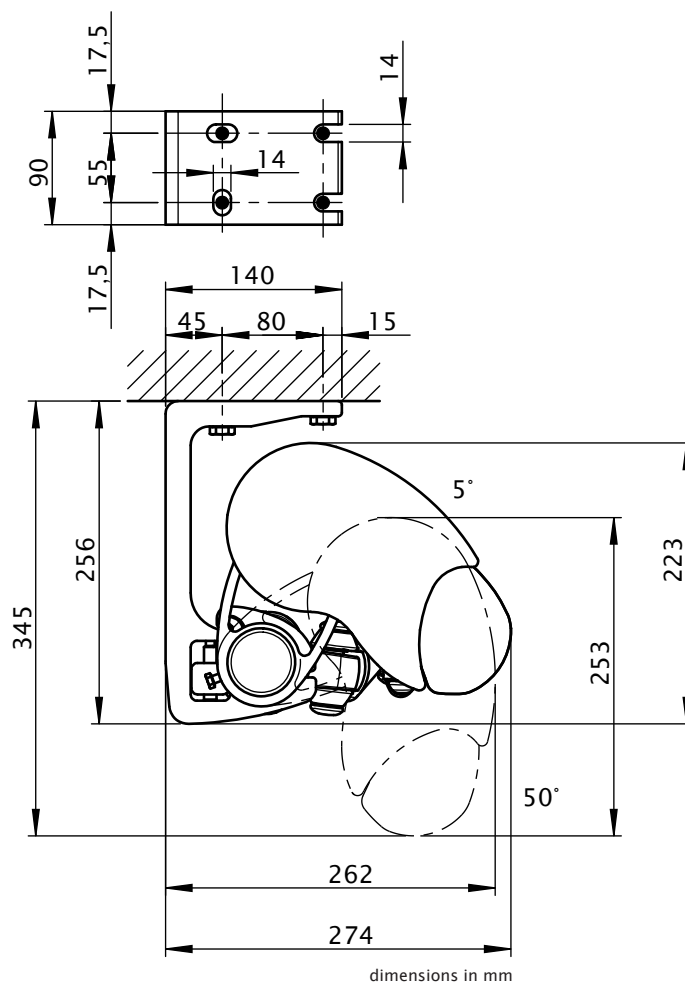

dimensions in mm

markilux 1500

Eaves/Roof timber fixture

Pull-out force [N=Newton] for the fixture bracket next to the arm according to EN 13561, wind resistance class 2

H [cm]	Torque										shear force									
	M [cm]										M [cm]									
	260	310	360	410	460	510	560	610	660	260	310	360	410	460	510	560	610	660		
	Md [Nm]										FS [N]									
150	116	132	147	163	178	194	210	225	241	1418	1617	1815	2014	2212	2411	2610	2808	3007		
200	182	207	232	256	281	306	331	355	380	2154	2454	2753	3053	3353	3653	3952	4252	4552		
250	---	297	333	368	404	440	476	511	616	---	3453	3875	4298	4720	5142	5565	5987	7178		
300	---	---	451	500	548	597	730	786	843	---	---	5190	5756	6323	6889	8388	9042	9696		
350	---	---	---	652	808	883	957	1031	---	---	---	---	7449	9213	10064	10915	11766	---		
HT	2					3					2					3				
BM	8					12					8					12				

The shear force are calculated from 2 fixture points per bracket, because depending on the roof pitch it cannot be guaranteed that 4 fixture points per bracket can be used.

M = overall awning width
 H = extension
 Md = torque value for the bracket next to the arm
 FS = shear force
 HT = bracket
 BM = no. of fixing points

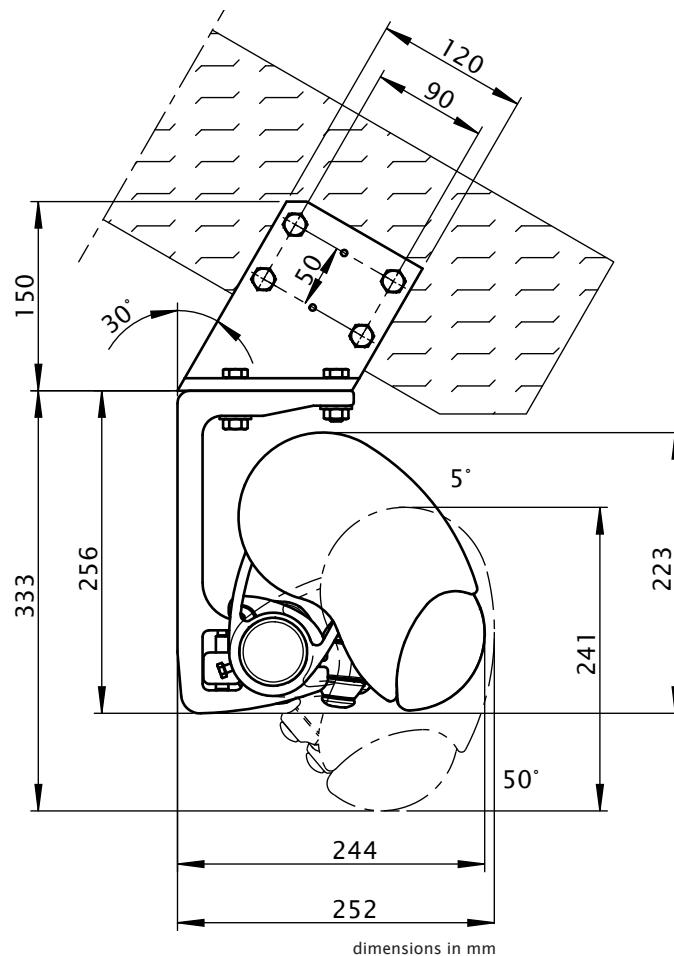

Eaves fixture with additional plate

Pull-out force [N=Newton] for the fixture bracket next to the arm according to EN 13561, wind resistance class 2

H [cm]	Torque									shear force								
	M [cm]									M [cm]								
	260	310	360	410	460	510	560	610	660	260	310	360	410	460	510	560	610	660
	Md [Nm]									FS [N]								
150	116	132	147	163	178	194	210	225	241	710	813	916	1019	1122	1225	1328	1432	1535
200	182	207	232	256	281	306	331	355	380	1041	1189	1338	1487	1635	1784	1933	2081	2230
250	---	297	333	368	404	440	476	511	616	---	1639	1843	2047	2251	2454	2658	2862	3412
300	---	---	451	500	548	597	730	786	843	---	---	2435	2703	2972	3240	3929	4237	4545
350	---	---	---	652	808	883	957	1031	---	---	---	---	3465	4272	4669	5066	5462	---
HT	2			3						2			3					
BM	4			6						4			6					

By using the additional flat plate, the shear force is reduced in comparison with conventional eaves fixture.

- M = overall awning width
- H = extension
- Md = torque value for the bracket next to the arm
- FS = shear force
- HT = bracket
- BM = no. of fixing points

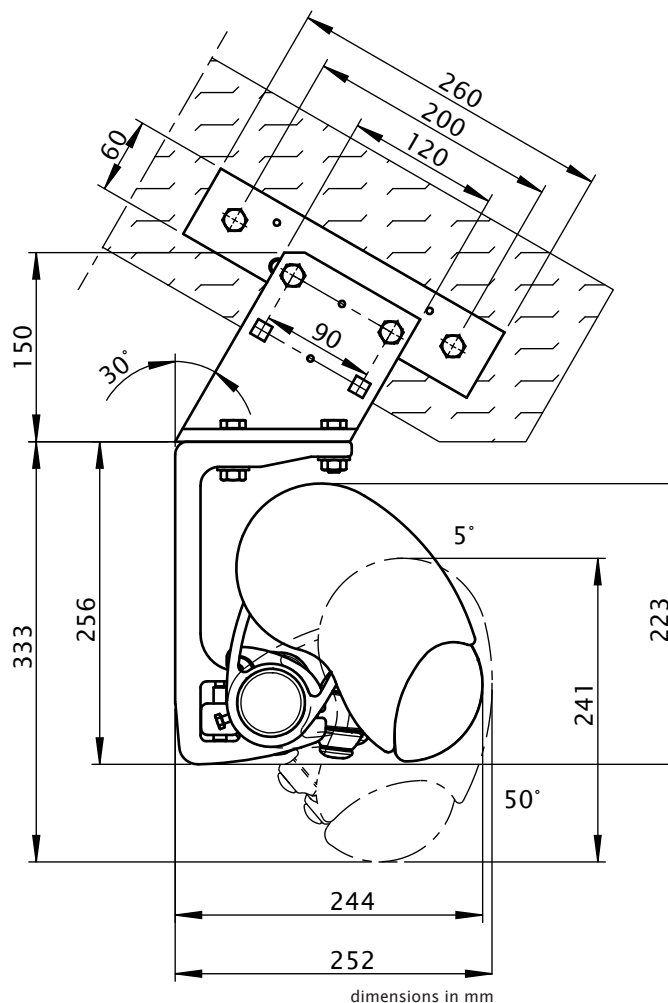

markilux 1500

Bracket range for awnings with 2 folding arms

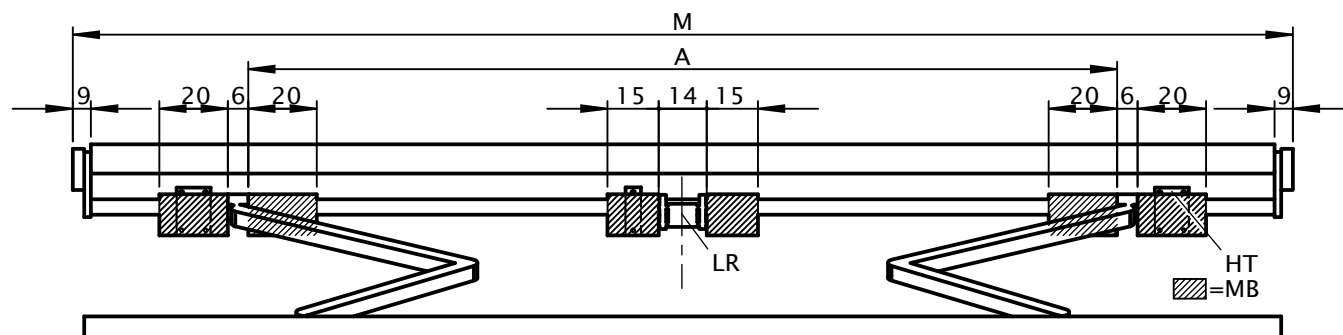

dimensions in cm

M [cm]	SB ZB	260 193-260	310 261-310	360 311-360	410 361-410	460 411-460	510 461-510	560 511-560	610 561-610	660 611-660
		A [cm]								
H [cm]	150	160 ■	220	250	280	320	390	425	460	500
	200	210 ▲	220 ■	250	280	320	390	425	460	500
	250	---	260 ▲	270 ■	280	320	390	425	460	500
	300	---	---	310 ▲	320 ■	320	390	425	460	500
	350	---	---	---	360 ▲	375 ■	390	425	460	---
W	HT BHT	45 mm	---				1			
		100 mm	2				2			
DE	HT BHT	45 mm	---				1			
		90 mm	2				2			
DA	HT BHT	2				3				

dimensions in cm

▲ = Note the minimum widths! In the case of small awnings the brackets can only be fitted inside the arms, position denoted by measurement A.

■ = coupled units are only available with junction roller in the standard widths, in other widths on request

M = overall awning width
 A = arm position
 HT = bracket
 MB = range for bracket fixture
 LR = Rolltex bearing with bracket is always situated under the central seam (depends on the width)
 SB = standard width
 ZB = intermediate width
 H = extension
 W = face fixture
 DE/DA = top fixture and eaves fixture
 HT | BHT = bracket quantity | width

If the brackets cannot be positioned in accordance with this table, make sure the actual measurements are noted on the order form!